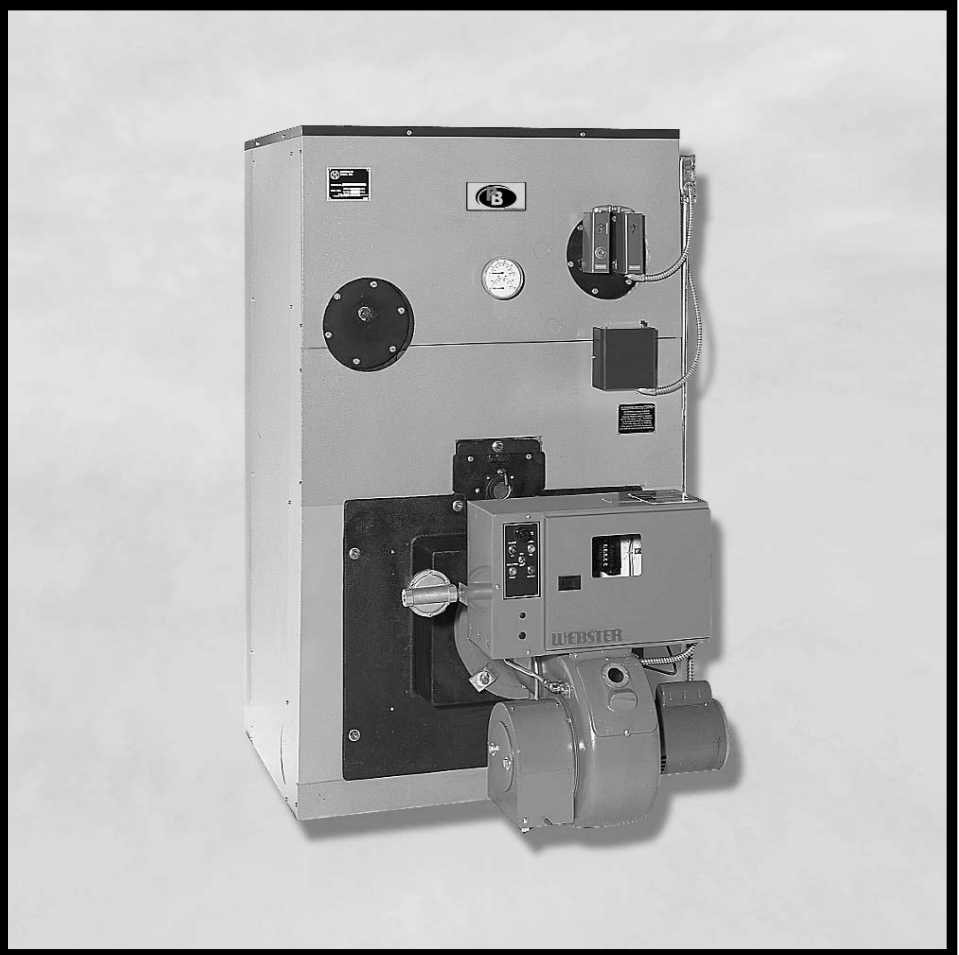


# Series **LC/LCE**

***Oil, Gas & Gas/Oil Boilers – Water***



## **Installation, Operation & Maintenance Manual**



PeerlessBoilers.com

# TABLE OF CONTENTS

<b>USING THIS MANUAL</b>	<b>1</b>	<b>5. VENTING</b>	<b>29</b>
A. INSTRUCTION MANUALS . . . . .	1	<b>6. INSTALL THE BURNER</b>	<b>29</b>
B. SPECIAL ATTENTION BOXES . . . . .	1	A. BURNER APPLICATION . . . . .	29
<b>1. PREINSTALLATION</b>	<b>2</b>	B. INSTALL BURNER MOUNTING PLATE . . .	29
A. ACCESSIBILITY CLEARANCES . . . . .	2	C. MOUNT THE BURNER . . . . .	29
B. CLEARANCE FROM COMBUSTIBLE CONSTRUCTION . . . . .	3	<b>7. CONNECT FUEL PIPING</b>	<b>31</b>
C. COMBUSTION AND VENTILATION AIR . . .	3	A. GENERAL . . . . .	31
D. CHIMNEY OR VENT . . . . .	3	B. INSTALL FUEL OIL PIPING . . . . .	31
E. BOILER SETTING . . . . .	4	C. INSTALL GAS SUPPLY PIPING . . . . .	31
F. INSTALLATION SURVEY . . . . .	5	D. TEST GAS SUPPLY PIPING . . . . .	31
G. PLANNING THE LAYOUT . . . . .	5	<b>8. INSTALL CONTROLS AND TRIM</b>	<b>33</b>
H. VERIFY COMPONENTS . . . . .	5	A. INSTALL SAFETY RELIEF VALVE . . . . .	33
<b>2. PLACE THE BOILER</b>	<b>10</b>	B. INSTALL DRAIN VALVE . . . . .	33
A. PACKAGED BOILER . . . . .	10	C. INSTALL LOW WATER COUTOUT(S) . . . .	33
B. ASSEMBLED BLOCK BOILER . . . . .	10	D. INSTALL CONTROLS & TRIM . . . . .	33
C. KNOCKDOWN BOILER – PLACING THE SECTIONS . . . . .	10	E. PIPE TANKLESS HEATERS IF USED . . . .	34
D. INSTALL COILS OR PLATES . . . . .	17	F. CONNECT SUPPLY WIRING . . . . .	34
E. HYDROSTATIC TEST THE BOILER . . . . .	17	G. INSTALL CONTROL WIRING . . . . .	34
F. APPLY CLEANOUT COVER PLATES . . . . .	18	<b>9. STARTING THE BOILER</b>	<b>37</b>
G. INSTALL FLUE COLLAR . . . . .	18	A. CHECK THE PIPING . . . . .	37
H. INSTALL FLUE BAFFLES . . . . .	19	B. FILL THE BOILER . . . . .	37
I. INSTALL CHAMBER LINER . . . . .	19	C. RUN BURNER CHECK-OUT . . . . .	37
<b>3. PIPE THE BOILER</b>	<b>20</b>	D. CHECK BOILER CONTROLS . . . . .	38
A. PREPARATION . . . . .	20	<b>10. MAINTENANCE</b>	<b>39</b>
B. SUPPLY AND RETURN PIPING . . . . .	20	A. PLACING BOILER IN OPERATION . . . . .	40
C. LOW SYSTEM TEMPERATURE . . . . .	20	B. TO SHUT DOWN THE BOILER . . . . .	40
D. CHILLED WATER SYSTEMS . . . . .	23	C. MAINTENANCE – ANNUAL . . . . .	40
E. HIGH FLOW RATE PIPING . . . . .	23	D. MONTHLY MAINTENANCE . . . . .	41
F. MULTIPLE BOILER INSTALLATIONS . . . .	23	E. DAILY MAINTENANCE . . . . .	41
<b>4. ASSEMBLE THE JACKET</b>	<b>27</b>	<b>11. BOILER RATINGS &amp; DIMENSIONS</b>	<b>42</b>
A. PREPARE THE PARTS . . . . .	27	<b>12. REPAIR PARTS</b>	<b>45</b>
B. APPLY JACKET SIDES AND CORNERS . . .	27	A. SERIES LC BOILER ASSEMBLY . . . . .	45
C. APPLY JACKET FRONT PANELS . . . . .	27	B. SERIES LCE BOILER ASSEMBLY . . . . .	48
D. APPLY JACKET REAR PANEL . . . . .	27		
E. APPLY JACKET TOP PANELS . . . . .	27		
F. APPLY PLATES AND LABELS . . . . .	27		

# USING THIS MANUAL

## A. INSTRUCTION MANUALS

The Series LC/LCE Installation, Operation & Maintenance Manual is divided into four basic sections:

1. Preinstallation (Section 1)
2. Installation (Sections 2 through 8)
3. Start-Up (Section 9)
4. Maintenance (Section 10)

## B. SPECIAL ATTENTION BOXES

Throughout this manual you will see special attention boxes intended to supplement the instructions and make special notice of potential hazards. These categories mean, in the judgment of PB Heat, LLC:



### DANGER

Indicates a condition or hazard which will cause severe personal injury, death or major property damage.



### WARNING

Indicates a condition or hazard which may cause severe personal injury, death or major property damage.



### CAUTION

Indicates a condition or hazard which will or can cause minor personal injury or property damage.



### NOTICE

Indicates special attention is needed, but not directly related to potential personal injury or property damage.

# 1. PREINSTALLATION

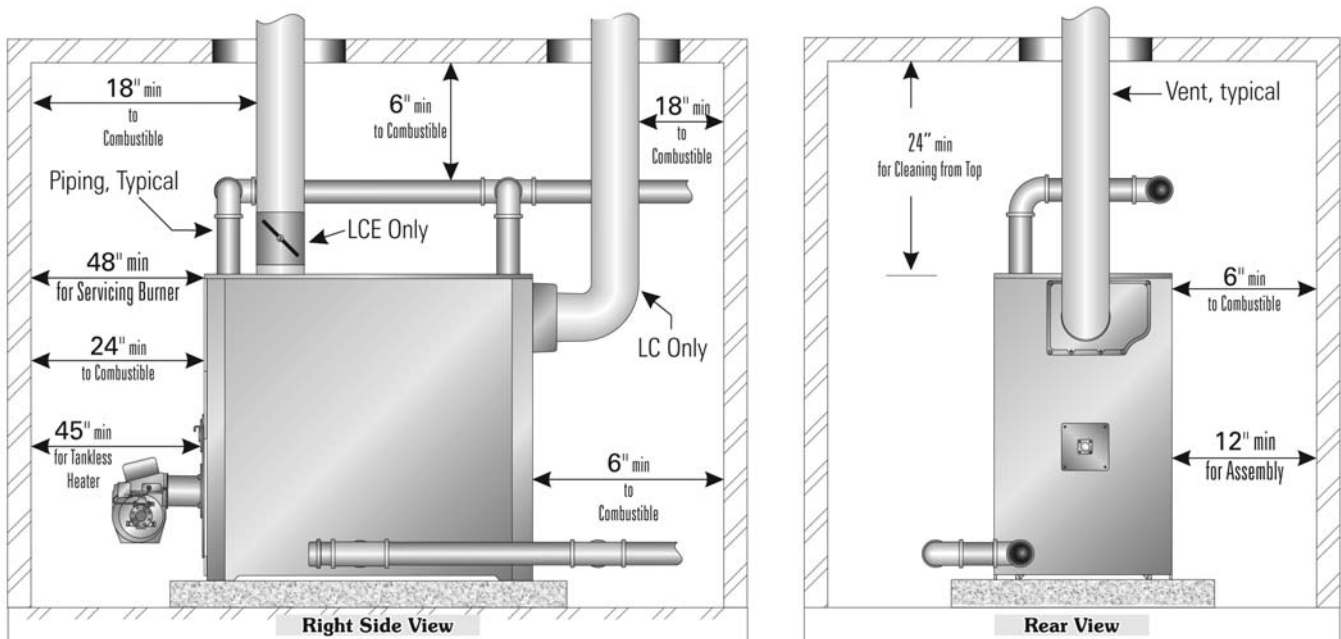
## ⚠ NOTICE

The equipment must be installed in accordance with installation requirements of the authority having jurisdiction or, in the absence of such requirements, to the current edition of the *National Fuel Gas Code*, ANSI Z223.1/NFPA 54.

Where required by the authority having jurisdiction, the installation must conform to *American Society of Mechanical Engineers Safety Code for Controls and Safety Devices for Automatically Fired Boilers*, ASME CSD-1.

Carefully read these instructions before beginning work. Understand all aspects of the installation. Contact your PB Heat's sales representative or customer service for help in answering questions.

This boiler must be installed by a qualified contractor. The boiler warranty can be voided if the boiler is not installed, maintained and serviced correctly.



**Figure 1.1: Clearance Requirements**

### A. ACCESSIBILITY CLEARANCES

1. Clearances for service and from combustible surfaces are the same for the LCE as for the LC. The following recommendations allow for *reasonable access to the boiler*. Follow local codes and requirements when setting actual layout. See Figure 1.1.
  - a) For installing, removing and servicing the burner: provide 48" between the front of the boiler and any adjacent wall or other appliance.
  - b) For access to the top of the boiler for cleaning flueways: provide 24" above top of jacket.
  - c) For accessing and servicing of level controls and inspection tappings (if used): provide 24" minimum from the right side of the boiler to any wall or obstruction.
  - d) For installation of jacket: provide at least 12" from the left side of the boiler to any wall or obstruction. More clearance may be needed for longer boilers unless the jacket is pre-assembled before placing the boiler.
  - e) For installation and removal of tankless heaters: provide 45" between the end of the boiler and any adjacent wall of obstruction. [This provides for all available tankless coils. The spacing can be closer for Heater Number X-1020 (allow 30") or Heater Number X-1021 (allow 35")].

**B. CLEARANCE FROM COMBUSTIBLE CONSTRUCTION**

Provide the following *minimum clearances to combustible construction*. See Figure 1.1.

1. Sides: 6"
2. Rear of Jacket: 6"
3. Front of Jacket: 24"
4. Top of Jacket: 24"
5. Hot Water Pipes: 6"
6. Vent or Chimney Connector: 18"

**C. COMBUSTION AND VENTILATION AIR**

1. The installation must provide adequate air for combustion and ventilation.
2. Unless the boiler room construction and natural air infiltration are sure to provide all the air needed, provide an opening or duct to the outside with a free cross sectional area of at least 1 square inch per 4000 Btuh input for all installed appliances. At high altitude, increase this requirement 4% for each 1000 feet above sea level.
3. The boiler room must never be under negative pressure. If exhaust fans or other equipment can cause a negative pressure in the boiler room, the air openings and equipment design must be engineered to assure a neutral or slightly positive pressure in the boiler room at all times of operation. If the equipment design and air openings cannot assure this, then the boiler must be located in an isolated room.
4. Using combustion air dampers:
  - a) If motorized dampers are used on the combustion and ventilation air openings, wire them such that they must open when the boiler tries to operate. They must include a switch which prevents the boiler from operating if they do not open. See Figure 1.2.

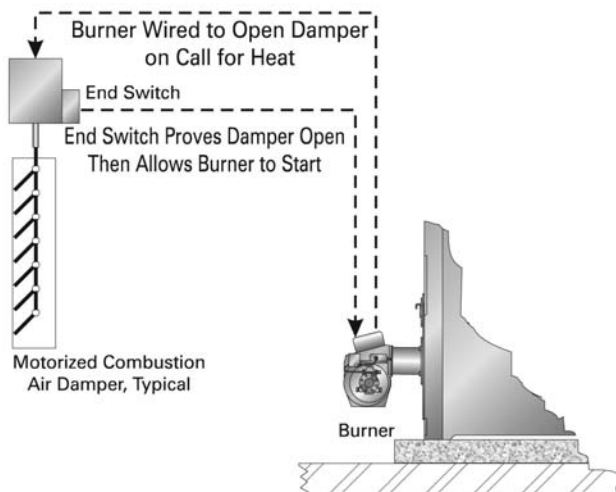


Figure 1.2: Motorized Vent Damper Interlock

**D. CHIMNEY OR VENT**

1. Inspect the existing chimney or vent system. Make sure it is in good condition. Inspect chimney liner and repair or replace if necessary.
2. The vent system and installation must be in accordance with the current edition of the American National Standard ANSI/NFPA 211, "Chimneys, Fireplaces, Vents, and Solid Fuel Burning Appliances", or applicable provisions of the local building codes. The venting requirements for the LCE are the same as for the LC. Figure 1.3 shows the top flue outlet required on LCE boilers.
3. Chimney/Vent Operation: The vent system must be sized and installed to remove all combustion products. If the vent system is not sized properly, the burner may not operate properly. This can cause poor combustion or sooting to occur.
4. If the vent terminates in an area where wind-generated downdrafts are likely, install a suitable vent cap which can control wind effects.
5. This boiler is designed to fire only with a pressurized fire box. The breeching and vent may be sized for negative, neutral or positive pressure (no more than 0.1 inches water column at the boiler outlet) as desired. But negative pressure overfire can cause lifting of the flame and poor combustion or overheating of the boiler crown sheet.
6. Forced draft breechings and vents must be sealed and of heavy gauge steel construction and must comply with all applicable codes of construction.
7. The vent diameter and minimum height for stub vents are listed in the Ratings and Dimensions Section of this manual. Always extend vent terminations at least 3 feet above the roof line. See Figure 1.3.

**WARNING**  
 Failure to provide adequate venting can result in severe property damage, personal injury or death.

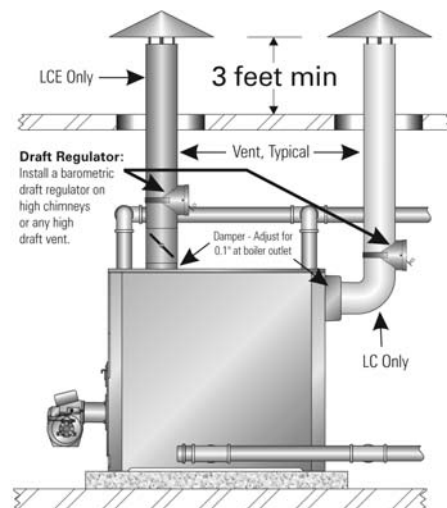


Figure 1.3: Vent Termination, Typical

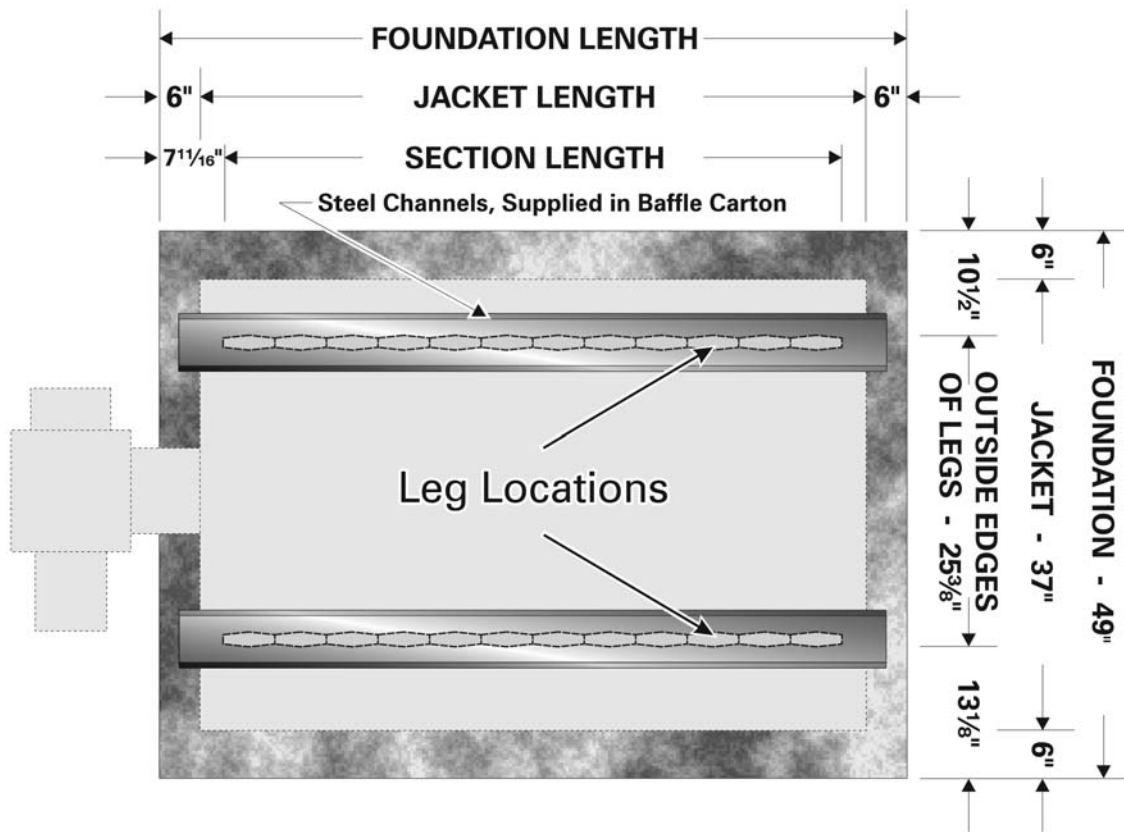


Figure 1.4: Foundation Layout

8. Exterior Vents:
  - a) Insulate sufficiently to ensure adequate draft and to prevent vent damage due to condensation.
9. Vent Connection to Boiler:
  - a) Support the weight of the vent system independently of the boiler flue connection.
  - b) Provide support of the vent connector (breaching) at maximum 12 foot intervals to prevent sagging and to provide a minimum upward slope of 1/4" per foot.
10. Do not vent natural draft appliances in a combined vent which operates under positive pressure.
11. Draft Regulator: Install a barometric draft regulator where using high chimney or any high draft vent. This is needed to prevent causing negative draft in the boiler. Excess draft will cause flame lifting and possible impingement.
12. The Draft Damper for the LCE boiler is a separate piece, shipped in the Top Flue Outlet Carton.
  - a) Install the Draft Damper as close as possible to the boiler flue outlet. It can be installed vertically or horizontally provided that the connecting vent piping and fittings are designed and installed for pressurized service.
  - b) Secure the damper to the vent with screws and seal the joints with a bead of high temperature silicone sealant (found in Section Assembly Kits).
  - c) The vent must be installed so it can be disconnected and the Top Flue Outlet removed for proper cleaning of the flueways.

### E. BOILER SETTING

1. If the boiler room floor is not level or if additional structural support is needed, provide a good, level foundation for the boiler with the minimum dimensions given in Table 1.1. The flooring and structural support system must be suitable for the operating weight of the boiler and any connected piping. Place the Steel Channels on the foundation as shown in Figure 1.4.
2. Do not operate the boiler until the foundation, if new concrete, has thoroughly cured. The concrete might be damaged if heated too quickly due to the entrained moisture remaining.

### WARNING

**Do not install this boiler on carpeting or any combustible flooring. A significant fire hazard could result, with potential for property damage, personal injury or death.**

3. If the boiler is installed in a penthouse or if wiring of any sort is run underneath the boiler foundation, construct the foundation with provision for air flow underneath between the main floor and the top of the boiler foundation.
  - a) An acceptable foundation would be concrete blocks laid with the openings lined up.

**Table 1.1: Foundation Lengths**

<b>Model</b>	<b>Foundation Length, Inches</b>
LC-04	37 <sup>15</sup> / <sub>16</sub>
LC-05	43
LC-06	48 <sup>7</sup> / <sub>16</sub>
LC-07	53 <sup>3</sup> / <sub>8</sub>
LC-08	58 <sup>9</sup> / <sub>16</sub>
LC-09	63 <sup>3</sup> / <sub>8</sub>
LC-10	68 <sup>7</sup> / <sub>16</sub>
LC-11	73 <sup>1</sup> / <sub>2</sub>
LC-12	78 <sup>9</sup> / <sub>16</sub>
LCE-13	83 <sup>3</sup> / <sub>4</sub>
LCE-14	88 <sup>13</sup> / <sub>16</sub>
LCE-15	93 <sup>7</sup> / <sub>8</sub>
LCE-16	98 <sup>5</sup> / <sub>16</sub>
LCE-17	104 <sup>1</sup> / <sub>8</sub>
LCE-18	109 <sup>3</sup> / <sub>16</sub>
LCE-19	114 <sup>1</sup> / <sub>4</sub>
LCE-20	119 <sup>7</sup> / <sub>16</sub>
LCE-21	124 <sup>1</sup> / <sub>2</sub>
LCE-22	129 <sup>9</sup> / <sub>16</sub>
LCE-23	134 <sup>5</sup> / <sub>8</sub>
LCE-24	139 <sup>11</sup> / <sub>16</sub>

- b) If the foundation must be a concrete slab, use an air cell high temperature insulating board, at least 1/2 inch thick, with aluminum backing, aluminum side up. 1/2 inch thick high temperature millboard with aluminum backing is acceptable as well. Place the insulating board on the slab between the steel channels.

**F. INSTALLATION SURVEY**

For new and existing installations, a Water Installation Survey is available from PB Heat, LLC. The survey will provide information on how a hot water boiler works with your specific system and will provide an overview of hot water system operation in general.

You can also use this survey to locate system problems which will have to be corrected. To obtain copies of the Water Installation Survey, contact your PB Heat representative or download it from PeerlessBoilers.com.

**G. PLANNING THE LAYOUT**

Prepare sketches and notes of the layout to minimize the possibility of interferences with new or existing equipment, piping, venting and wiring.

**H. VERIFY COMPONENTS**

1. Packaged: All components should be inside crate. In some cases the burner may be shipped separately. Optional equipment, such as barometric draft dampers, may also be shipped separately.
2. Knockdown: All components shipped for field assembly. See Table 1.2 for standard components. See Tables 1.3 through 1.8 for optional components.
  - a) Channel Rails
  - b) Sections
  - c) Assembly Kit Carton(s): Includes flow port gaskets, tie rods with hardware, high temperature rope, and cleanout cover plates.
  - d) Flue Box Carton: Includes flue box, rear flue cover plate (LCE only), rear observation assembly and port cover plates.
  - e) Baffle Carton
    - i) LC: Includes baffles, combustion chamber liner and rating label.
    - ii) LCE-21 through LCE-24: Baffles
  - f) Jacket Cartons: Include ASME plate
  - g) Draft Damper (LCE only)
  - h) Label Carton (LCE only)
  - i) Burner Mounting Plate
  - j) Trim Carton: Includes safety relief valve and temperature-pressure gage
  - k) Control Carton: Limit controls
  - l) Tankless Heater(s)
  - m) Additional controls and fittings
3. Assembled Block: Same as knockdown except channel rails, sections and assembly kit cartons are assembled into a block as a single shipping level component.

**Table 1.2A: Series LC Shipping List**

Boiler Model Number	Channel Rail Bundle	Standard Sections (See Table 1.3 for Options)				Assembly Kit Ctns.			Flue Ctn.			Jacket Cartons (Tbl 1.4, 1.5 Options)		
		Front	Back	Plain Interm.	1" LWCO Interm.	3" Tap Interm.	Baffle Carton	Contents See Below Item 1	Contents See Below Item 2	Front/Rear Panels Hardware	Contents See Below Item 2	Front/Rear Panels Hardware	Top/Side Panels Hardware Chamber Liner	
LC-04	Quantity	1	1	1	1		1	1	1	1	1	1	1	
	Part No.	LC-1001	LC-1007	LC-1000	LC-1000-1		LC-1023	LC-1022	LC-5004	LC-5004	LC-6016	LC-6017		
	Label						LC-04	A	A			A		
LC-05R	Stock Code	86000	86022	86004	86005		85004	86050	86040	86040	86030	86031		
	Quantity	1	1	2	1		1	1	1	1	1	1		
	Part No.	LC-1001	LC-1007	LC-1000	LC-1000-1		LC-1023	LC-1022-1	LC-5004	LC-5004	LC-6016	LC-6017-1		
LC-05	Label						LC-05	B	A			B		
	Stock Code	86000	86022	86004	86005		85105	86051	86040	86040	86030	86032		
	Quantity	1	1	2	1		1	1	1	1	1	1		
LC-06	Part No.	LC-1001	LC-1007	LC-1000	LC-1000-1		LC-1023-1	LC-1022-1	LC-5004	LC-5004	LC-6016	LC-6017-1		
	Label						LC-05	B	A			B		
	Stock Code	86000	86022	86004	86005		85005	86051	86040	86040	86030	86032		
LC-07	Quantity	1	1	3	1		1	1	1	1	1	1		
	Part No.	LC-1001	LC-1007	LC-1000	LC-1000-1		LC-1023-2	LC-1022-2	LC-5004-1	LC-5004-1	LC-6016	LC-6017-2		
	Label						LC-06	C	B			C		
LC-08	Stock Code	86000	86022	86004	86005		85006	86052	86041	86041	86030	86033		
	Quantity	1	1	4	1		1	1	1	1	1	1		
	Part No.	LC-1001	LC-1007	LC-1000	LC-1000-1		LC-1023-3	LC-1022-3	LC-5004-1	LC-5004-1	LC-6016	LC-6017-3		
LC-09	Label						LC-07	D	B			D		
	Stock Code	86000	86022	86004	86005		85007	86053	86041	86041	86030	86034		
	Quantity	1	1	4	1	1	1	1	1	1	1	1		
LC-10	Part No.	LC-1001	LC-1007	LC-1000	LC-1000-1	LC-1003	LC-1023-4	LC-1022	LC-1022-1	LC-5004-1	LC-6016	LC-6017	LC-6017-1	
	Label						LC-08	A	B	B		A	B	
	Stock Code	86000	86022	86004	86005	86008	85008	86050	86051	86041	86030	86031	86032	
LC-11	Quantity	1	1	5	1	1	1	2		1	1	2		
	Part No.	LC-1001	LC-1007	LC-1000	LC-1000-1	LC-1003	LC-1023-5	LC-1022-1		LC-5004-2	LC-6016	LC-6017-1		
	Label						LC-09	B		C		B		
LC-12	Stock Code	86000	86022	86004	86005	86008	85009	86051		86042	86030	86032		
	Quantity	1	1	6	1	1	1	1	1	1	1	1	1	
	Part No.	LC-1001	LC-1007	LC-1000	LC-1000-1	LC-1003	LC-1023-6	LC-1022-1	LC-1022-2	LC-5004-2	LC-6016	LC-6017-1	LC-6017-2	
LC-13	Label						LC-10	B	C	C		B	C	
	Stock Code	86000	86022	86004	86005	86008	85010	86051	86052	86042	86030	86032	86033	
	Quantity	1	1	7	1	1	1	2		1	1	2		
LC-14	Part No.	LC-1001	LC-1007	LC-1000	LC-1000-1	LC-1003	LC-1023-7	LC-1022-2		LC-5004-2	LC-6016	LC-6017-2		
	Label						LC-11	C		C		C		
	Stock Code	86000	86022	86004	86005	86008	85011	86052		86042	86030	86033		
LC-15	Quantity	1	1	8	1	1	1	1	1	1	1	1	1	
	Part No.	LC-1001	LC-1007	LC-1000	LC-1000-1	LC-1003	LC-1023-8	LC-1022-2	LC-1022-3	LC-5004-2	LC-6016	LC-6017-2	LC-6017-3	
	Label						LC-12	C	D	C		C	D	
LC-16	Stock Code	86000	86022	86004	86005	86008	85012	86052	86053	86042	86030	86033	86034	
	Quantity	1	1	8	1	1	1	1	1	1	1	1	1	
	Part No.	LC-1001	LC-1007	LC-1000	LC-1000-1	LC-1003	LC-1023-9	LC-1022-2	LC-1022-3	LC-5004-2	LC-6016	LC-6017-2	LC-6017-3	

1 Assembly Kit Cartons Contents: Flow Port Gaskets, Silicone Sealant, Tie Rods, Washers, Tie Rod Nuts, Section Seal Rope, Spray Adhesive, Cleanout Plates, Mounting Hardware  
 2 Flue Box Carton Contents: Flue Box, Seal Rope, Observation Assembly, Coil Cover Plates, Cover Plate Gaskets, Mounting Hardware



Table 1.2B: Series LCE Shipping List

Boiler Model Number	Channel Rail Bundle	Standard Sections (See Table 1.3 for Options)				Baffle Carton	Assembly Kit Cartons				Flue Cn. Jacket Cartons (See Table 1.4, 1.5 for Options)	Draft Damper	Lbl. Cn.			
		Front	Top Flue Interm.	1" LWCO Interm.	3" Tap Interm.		Plain Interm.	Back	Flow Port Gaskets, Silicone Sealant, The Rods, Washers, The Rod Nuts, Section Seal Rope, Spray Adhesive, Cleanout Plates, Mounting Hardware	Contents See Below Item 1				Front/Rear Panels Hardware	Top/Side Panels Hardware Chamber Liner	
LCE-13	Quantity	2	1	3	1	1	6	1	1	1	1	1	1	1	1	1
	Part No.		LC-1001	LCE-1056	LC-1000-1	LC-1003	LC-1000	LC-1007				LCE-6016	LCE-6017-1	LCE-6023	S-5007-3	LCE-8028
	Label								C	E		A	B	E	A	
LCE-14	Quantity	2	1	3	1	1	7	1	1	1	1	2	2	1	1	1
	Part No.		LC-1001	LCE-1056	LC-1000-1	LC-1003	LC-1000	LC-1007				LCE-6016	LCE-6017-1	LCE-6023	S-5007-3	LCE-8028-1
	Label								D	E		B		E	A	
LCE-15	Quantity	2	1	3	1	1	8	1	1	1	1	1	1	1	1	1
	Part No.		LC-1001	LCE-1056	LC-1000-1	LC-1003	LC-1000	LC-1007				LCE-6016	LCE-6017-2	LCE-6023	S-5007-3	LCE-8028-2
	Label								A	B	E	D	C	E	A	
LCE-16	Quantity	2	1	3	1	1	9	1	1	1	1	1	1	1	1	1
	Part No.		LC-1001	LCE-1056	LC-1000-1	LC-1003	LC-1000	LC-1007				LCE-6016	LCE-6017-2	LCE-6023	S-5007-3	LCE-8028-3
	Label								B	E		C		E	A	
LCE-17	Quantity	2	1	3	1	1	10	1	1	1	1	1	1	1	1	1
	Part No.		LC-1001	LCE-1056	LC-1000-1	LC-1003	LC-1000	LC-1007				LCE-6016	LCE-6017-1	LCE-6023	S-5007-3	LCE-8028-4
	Label								B	C	E	D	A	B	E	A
LCE-18	Quantity	2	1	3	1	1	11	1	1	1	1	1	1	1	1	1
	Part No.		LC-1001	LCE-1056	LC-1000-1	LC-1003	LC-1000	LC-1007				LCE-6016	LCE-6017-1	LCE-6023	S-5007-4	LCE-8028-5
	Label								C	E		B		E	B	
LCE-19	Quantity	2	1	3	1	1	12	1	1	1	1	1	1	1	1	1
	Part No.		LC-1001	LCE-1056	LC-1000-1	LC-1003	LC-1000	LC-1007				LCE-6016	LCE-6017-1	LCE-6023	S-5007-4	LCE-8028-6
	Label								C	D	E	E	C	E	B	
LCE-20	Quantity	2	1	3	1	1	13	1	1	1	1	1	1	1	1	1
	Part No.		LC-1001	LCE-1056	LC-1000-1	LC-1003	LC-1000	LC-1007				LCE-6016	LCE-6017-1	LCE-6023	S-5007-4	LCE-8028-7
	Label								D	E		A	B	E	B	
LCE-21	Quantity	2	1	3	1	1	13	1	1	1	1	1	1	1	1	1
	Part No.		LC-1001	LCE-1056	LC-1000-1	LC-1003	LC-1000	LC-1007	LCE-1074			LCE-6016	LCE-6017-1	LCE-6023	S-5007-4	LCE-8028-8
	Label								A	B	D	E	E	E	B	
LCE-22	Quantity	2	1	3	1	1	14	1	1	1	1	1	1	1	1	1
	Part No.		LC-1001	LCE-1056	LC-1000-1	LC-1003	LC-1000	LC-1007	LCE-1074			LCE-6016	LCE-6017-1	LCE-6023	S-5007-4	LCE-8028-9
	Label								B	D	E	E	B	E	B	
LCE-23	Quantity	2	1	3	1	1	15	1	1	1	1	1	1	1	1	1
	Part No.		LC-1001	LCE-1056	LC-1000-1	LC-1003	LC-1000	LC-1007	LCE-1074			LCE-6016	LCE-6017-1	LCE-6023	S-5007-4	LCE-8028-10
	Label								B	C	D	E	E	E	B	
LCE-24	Quantity	2	1	3	1	1	16	1	1	1	1	1	1	1	1	1
	Part No.		LC-1001	LCE-1056	LC-1000-1	LC-1003	LC-1000	LC-1007	LCE-1074			LCE-6016	LCE-6017-1	LCE-6023	S-5007-4	LCE-8028-11
	Label								C	D	E	E	B	E	B	

1 Flue Box Carton Contents: Top Flue Plate, Rear Flue Cover, Seal Rope, Observation Assembly, Coil Cover Plates, Cover Plate, Gaskets, Mounting Hardware

## PREINSTALLATION

**Table 1.3: Standard and Optional Sections for Knockdown Boilers**

Sections		50 psig MAWP				80 psig MAWP			
		Standard No Inspection Tappings		w/Inspection Tappings		No Inspection Tappings		w/Inspection Tappings	
<b>Front</b>	Part #/UPC	LC-1001	86000	LC-1013	86010	LC-1001-2	86002	LC-1013-2	86012
<b>Plain Interm.</b>	Part #/UPC	LC-1000	86004	LC-1014	86014	LC-1000-2	86006	LC-1014-1	86015
<b>Top Flue Interm.</b>	Part #/UPC	LCE-1056	86100	LCE-1064	86110	LCE-1056-1	86111	LCE-1064-1	86112
<b>LWCO Interm.</b>	Part #/UPC	LC-1000-1	86005	LC-1014-2	86092	LC-1000-3	86007	LC-1014-3	86093
<b>3" Tap. Interm.</b>	Part #/UPC	LC-1003	86008	LC-1015	86016	LC-1003-2	86009	LC-1015-1	86017
<b>Closed Back</b>	Part #/UPC	LC-1007	86022	LC-1016	86018	LC-1007-2	86024	LC-1016-2	86020
<b>Coil Back</b>	Part #/UPC	LC-1002	86036	LC-1017	86026	LC-1002-2	86038	LC-1017-2	86028

**Table 1.4: Standard and Optional Jacket Cartons, Front/Back Panels**

Standard 50 psig MAWP	86030
30 psig MAWP	86059
80 psig MAWP	86058

Note: 80 psig MAWP not available in Canada.

**Table 1.5: Standard and Optional Jacket Cartons, Top/Side Panels**

Jacket Label	Standard (No Inspection Tappings)	With Inspection Tappings
A	86031	86101
B	86032	86102
C	86033	86103
D	86034	86104
E	86094	86097

Note: Boilers with inspection tappings in front and back sections only use standard cartons.

**Table 1.6A: Burner Mounting Plates**

Model		Boiler Model									
		LC-04	LC-05R	LC-05	LC-06	LC-07	LC-08	LC-09	LC-10	LC-11	LC-12
<b>Beckett</b>	CF-800	86070*	86070*								
	CF-1400			86069*	86069*	86069*					
	CF-2300						86074*	86074*	86074*	86074*	86074*
<b>Carlin</b>	301CRD	86070*	86070*								
	702CRD			86069*	86069*	86069*	86069*				
	801CRD							86073	86073	86073	86073
<b>Gordon Piatt</b>	S4.2	86070*	86070*								
	R6.2			86078							
	R6.3				86078						
	R8.1					86079	86079				
	R8.2							86079	86079	86079	
	R8.3									86079	
<b>Power Flame</b>	C1	86071	86071	86071	86071	86071					
	C2						86076	86076	86076	86076	86076
	J15A	86072	86072								
	J30A			86072	86072	86072					
	J50A						86077	86077	86077	86077	
<b>Webster</b>	JB1	86071	86071	86071	86071	86071	86075	86075	86075	86075	86075

\* Standard Burner Mounting Plate

**Table 1.6B: Burner Mounting Plates**

Model		Boiler Model											
		LCE-13	LCE-14	LCE-15	LCE-16	LCE-17	LCE-18	LCE-19	LCE-20	LCE-21	LCE-22	LCE-23	LCE-24
Beckett	CF2300AKG	86074*											Not Available
	CF2300AKB		86083*	86083*									
	CF2500				86074*	86074*							
	CF3500AKM						86083*	86083*	86083*				
	CF3500AKL									86080*	86080*		
Carlin	801CRD	86073	86073										N/A
	1050FFD			86086	86086								
	1150FFD					86087	86087	86087	86087	86087	86087	86087	
Gordon Piatt	R10.9	86088											
	R10		86088	86088	86088	86088	86088						
	R10.1							86088	86088	86088	86088		
	R10.2											86088	86088
Power Flame	C2	86076	86076	86076									
	C3				86080	86080	86080	86080	86080	86080	86080	86080	86080
Webster	JB2	86081	86081	86081	86081	86081	86081	86081	86081	86081	86081	86081	86081

\* Standard Burner Mounting Plate

**Table 1.7: Trim Cartons**

Model	Output <sup>1</sup>		
	30 psig	50 psig	80 psig
LC-04	87030	87050	87080
LC-05R	87030	87050	87080
LC-05	87030	87050	87080
LC-06	87030	87050	87080
LC-07	87031	87050	87080
LC-08	87031	87050	87080
LC-09	87032	87051	87080
LC-10	87032	87051	87081
LC-11	87032	87051	87081
LC-12	87032	87051	87081
LCE-13	87032	87052	87081
LCE-14	87033	87052	87081
LCE-15	87033	87052	87082
LCE-16	87033	87052	87082
LCE-17	87033	87052	87082
LCE-18	87033	87052	87082
LCE-19	87034	87052	87082
LCE-20	87034	87053	87802
LCE-21	87034	87053	87082
LCE-22	87034	87053	87082
LCE-23	87034	87053	87082
LCE-24	87034	87053	87082

<sup>1</sup> Safety Relief Valve selection based on capacity determined by boiler output (Gross I=B=R Output). Applies to most locations in United States and Canada.

**Table 1.8: Control Cartons**

Model	Water
LC-04 Through LCE-24	88510

## 2. PLACE THE BOILER

### A. PACKAGED BOILER

1. Remove crate top and sides. Remove any loose cartons. Remove burner support pedestal and nipple, if supplied
2. Lift boiler off crate pallet. Move to location determined in Chapter 1: Preinstallation.
3. Remove lifting frame and hardware.
4. Re-install burner support pedestal and nipple if necessary.
5. Proceed to Chapter 3: Piping the Boiler.

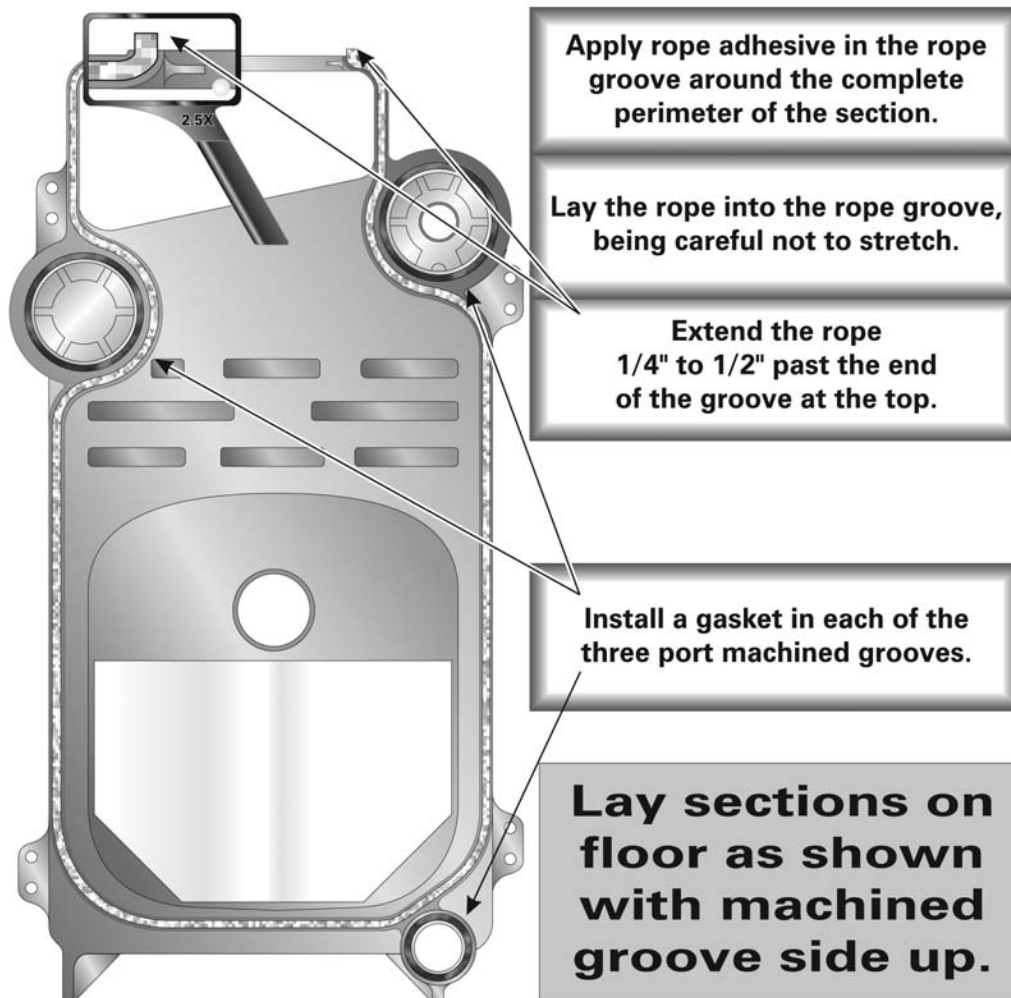
### B. ASSEMBLED BLOCK BOILER

1. Move block to location determined in Chapter 1: Preinstallation.

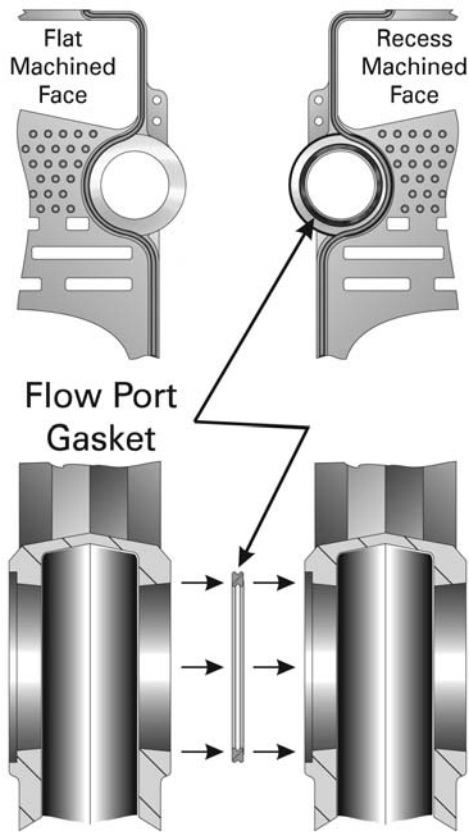
2. Remove lifting frame and hardware.
3. Proceed to Section D: Install Coils or Plates

### C. KNOCKDOWN BOILER

1. Place channel rails as shown in Figure 1.4.
2. Open the Section Assembly Kit cartons. These cartons contain the parts needed for assembly of the sections.
3. Place the Back Section on the floor as shown in Figure 2.1.
4. The Back Section combustion chamber area is lined with a ceramic fiber blanket liner. Make sure the liner is in good condition. Minor tears are not a problem, but there should be no holes in the insulation.



**Figure 2.1: Lay Sections on Floor and Apply Rope Seal and Gaskets**



**Figure 2.2: Flow Port Machining & Gasket**

**CAUTION**

Gaskets will be damaged by petroleum or its derivatives. Completely remove all solvent residue before placing gaskets.

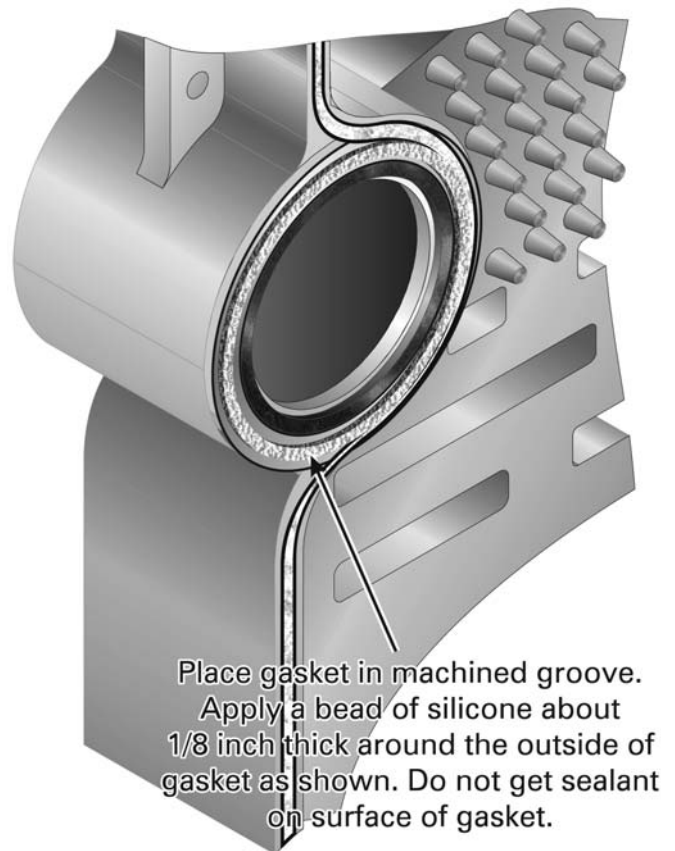
Do not use petroleum based compounds in the boiler.

5. Clean the area around the flow ports and in the seal recess. Use solvent and a clean cloth to thoroughly clean all of the sealing surfaces. Remove all foreign matter to assure a water tight seal when the sections are drawn together.
6. Place a Flow Port Gasket in each of the three flow port recesses as shown in Figures 2.1 and 2.2.
7. Apply spray adhesive in the rope groove around the perimeter of the section.
8. Place the sealing rope completely around the rope groove, being careful not to stretch the rope. Extend the rope from 1/4" to 1/2" past the end of the groove on both sides of the cleanout opening on top of the section. This will assure a gas tight seal when the cleanout cover plate is applied.
9. Apply a bead of silicone sealant around each flow port as shown in Figure 2.3. Do not get sealant on the flow port gaskets.

**WARNING**

The sections are heavy and must be supported securely.

10. Lift up the Rear Section and move into position on the steel channels on the boiler foundation.
11. Screw a 3" pipe at least 30 inches long into the lower 3" tapping on the back of the Rear Section as shown in Figure 2.4. Place a block under the pipe as shown in the figure and use as a brace during assembly.
12. Place a Plain Intermediate Section on the floor and prepare as above.
13. Carefully place the Intermediate Section against the Rear Section and visually line up the flow ports as close as possible.
14. Insert a tie rod with one nut and washer applied into each of the four tie rod lugs. See Figures 2.5 and 2.6.
15. Place the nut and washer on the other end of the tie rod and draw finger tight.



**Figure 2.3: Apply Silicone Sealant**

**⚠ WARNING**

**SECTIONS ARE TOP HEAVY.  
HANDLE WITH CARE TO  
AVOID TIPPING OR FALLING.**

**Level Each Section:**

Place the first intermediate section next to the rear section as shown. Use a spirit level to make sure the sections are plumb. Check the level as each additional intermediate section is added.

**Temporary Support Pipe**

Screw a 3" pipe at least 30 inches long into the lower (return) tapping in the rear section.



**Figure 2.4: Install Additional Sections. Use level on each section as tie rod bolts are drawn up.**

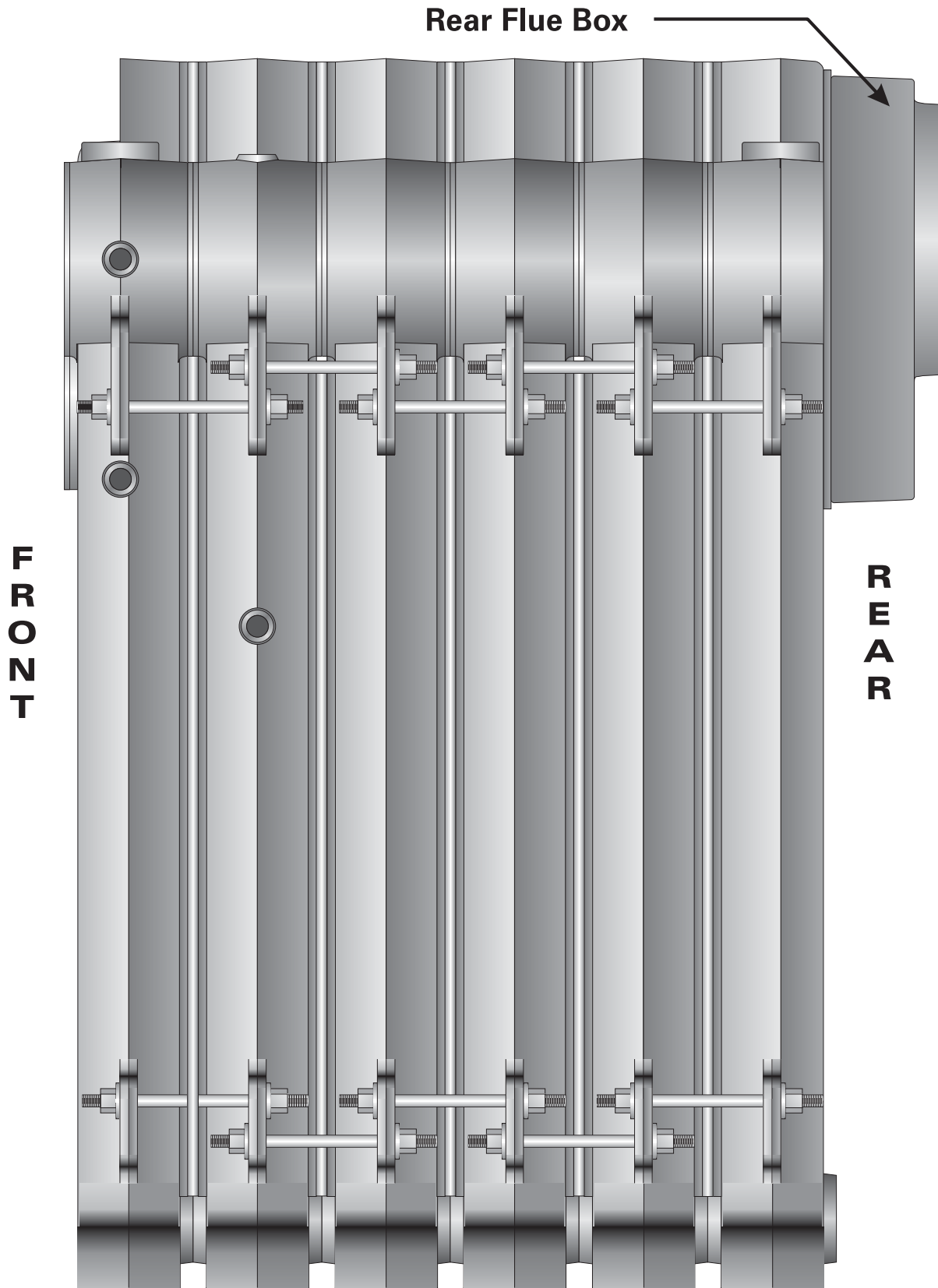


Figure 2.5: Series LC Boiler Assembly – Right Side View

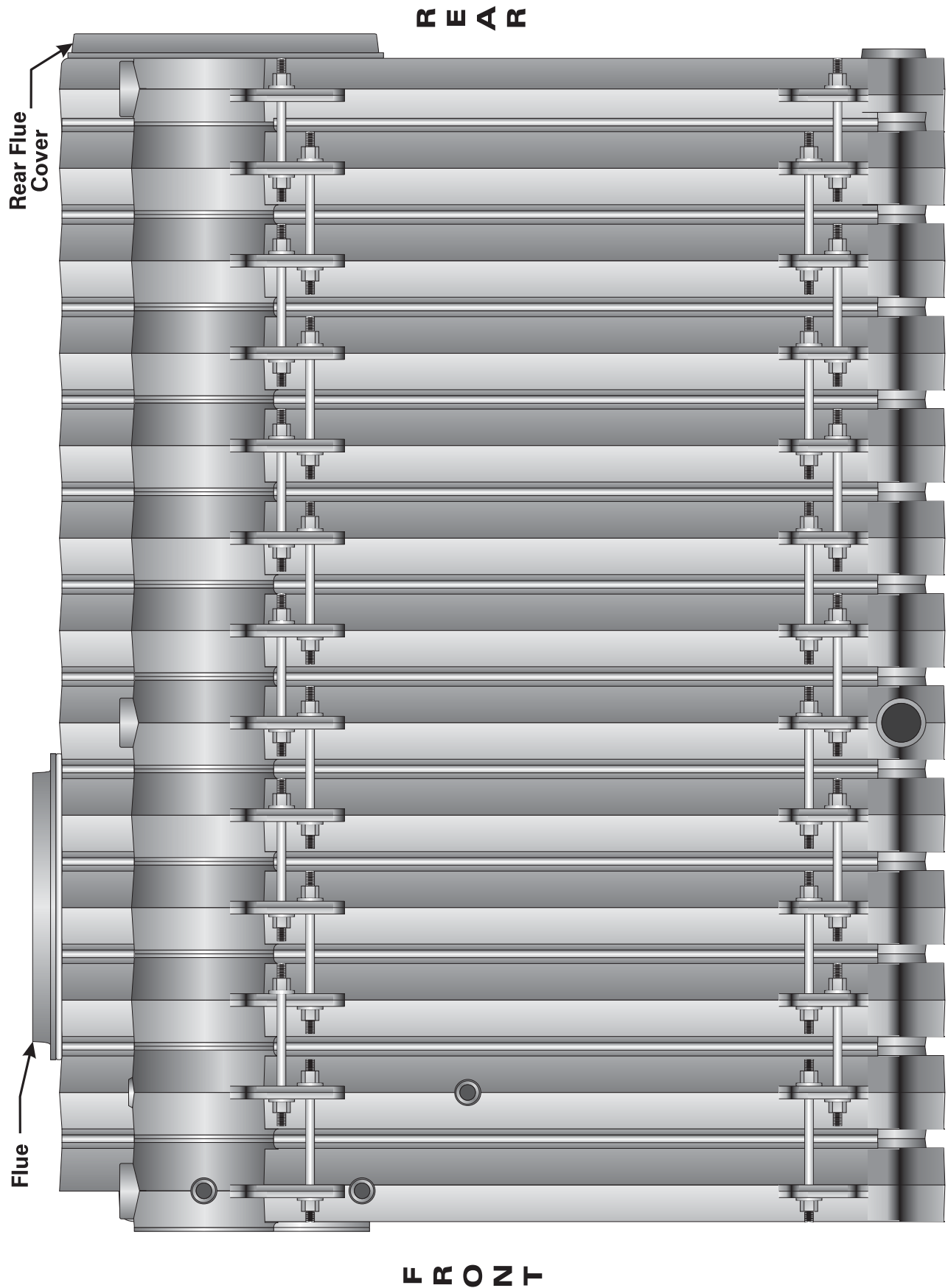


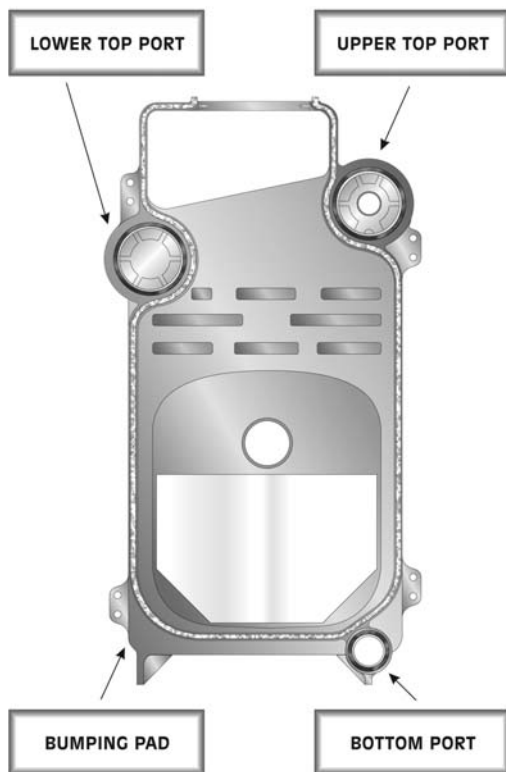
Figure 2.6: Series LCE Boiler Assembly – Right Side View



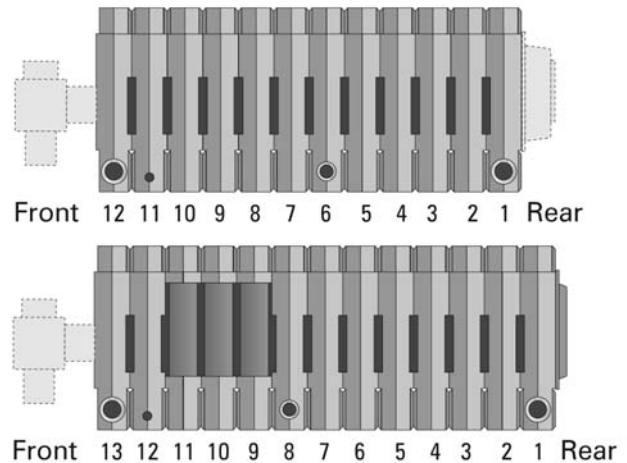
16. To properly assemble LC/LCE sections in the field, the following steps *must* be followed to ensure that no damage occurs to the tie rod lugs. A 0-100 ft-lbs torque wrench is required.
- Use a spirit level as shown in Figure 2.4 to check the alignment of the sections as the nuts are drawn up. Keep the sections plumb.
  - Draw the sections together evenly, in three rotations. Torque each port to 20 ft-lbs for the first rotation, then to 40 ft-lbs for the second rotation, then to 60 ft-lbs for the third rotation. Use the following sequence until all three ports touch metal-to-metal at 60 ft-lbs. See Figure 2.7 for port reference.
    - First: Lower Top Port
    - Second: Bottom Port
    - Third: Upper Top Port
  - Tighten these (3) three locations only to a torque value of 60 ft-lbs. **DO NOT EXCEED.**
  - After the three ports have been tightened to 60 ft-lbs, tighten the draw rod at the bumping pads until metal-to-metal contact is reached. This will assure a proper gas tight seal and prevent the products of combustion from migrating into the boiler room.

17. Repeat with the remaining sections.
- Save the LWCO Intermediate with two 1" tappings (for level control) for use as the section closest to the front section.
  - Place the Intermediate Section with 3" top tapping (Tapped Intermediate) in the position given in Figure 2.9.
  - LCE ONLY. Save the (3) Top Flue Outlet Intermediates (with wide opening in top of the flue collector) for use as the sections closest to the LWCO Intermediate Section. See Figure 2.9.
    - The sequence from Front to Rear is:
      - Front Section
      - 1" Low Water Cut-off Intermediate
      - Three (3) Top Flue Outlet Intermediates
    - The remaining intermediate sections are 3" Tapped Intermediates or Plain Intermediates as shown in Figure 2.8 and Figure 2.9.

**WARNING**  
Do not exceed the manufacturer's torque recommendations.



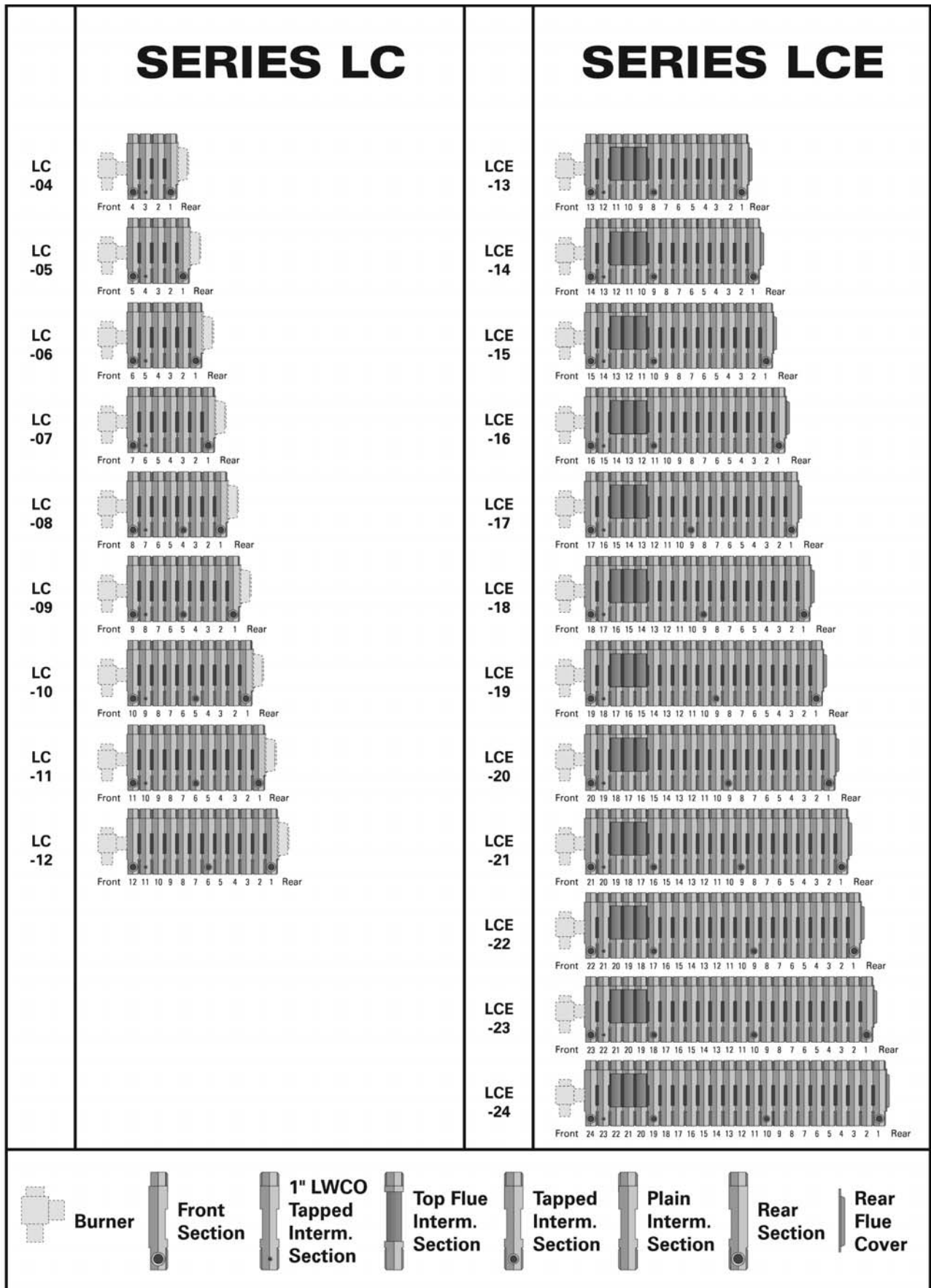
**Figure 2.7: Torque Specification/Procedure**



**Figure 2.8: Section Positioning Numbering**

**Table 2.1: Section Numbering Sequence**

Model	Place a Tapped Intermediate Section at Position (Numbered Rear to Front)
LC-04	NA
LC-05	NA
LC-06	NA
LC-07	NA
LC-08	4
LC-09	5
LC-10	5
LC-11	6
LC-12	6
LCE-13	8
LCE-14	9
LCE-15	10
LCE-16	11
LCE-17	9
LCE-18	9
LCE-19	9
LCE-20	9
LCE-21	9, 16
LCE-22	9, 17
LCE-23	10, 18
LCE-24	10, 19



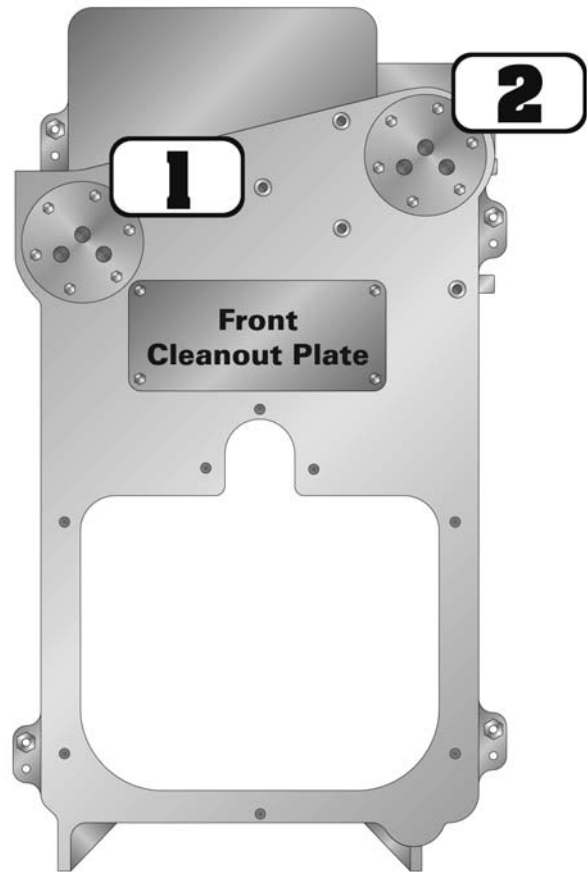
**Figure 2.9: LC/LCE Boiler Section Assembly Sequence**

**D. INSTALL COILS OR PLATES**

1. Remove the coil cover plates, gaskets and mounting hardware, located in the Flue Box Carton.
2. Install tankless heaters, if used, in openings #1 and #2. See Figure 2.10 and Table 2.2.
3. Place the cover plates and gaskets over any unused heater openings. Place the cover plate with two 3/4" NPT tapings on the upper flow port opening (Position #2) of the Front Section.

**E. HYDROSTATIC TEST THE BOILER**

1. Install a drain valve in the Rear Section, Tapping 13. See Figure 8.2.
2. Provide a water supply line to the boiler.
3. Plug all open tapings in the boiler.
4. Provide a means to vent air as the boiler fills.
5. Fill the boiler with water, venting air as water level rises.
6. Pressurize boiler to:
  - 75 psig for 50 psig sections.
  - 120 psig for 80 psig sections.
  - **DO NOT EXCEED THESE PRESSURES.**
  - a) Maintain pressure while checking all joints and fittings for leaks.
7. After inspection is complete, drain the boiler and remove plugs from tapings that are to be used.



**Figure 2.10: Tankless Coil Openings**

**Table 2.2: Tankless Coil Ratings**

Model	Heater No. X-1020		Heater No. X-1021		Heater No. X-1022		Two Heaters No. X-1020		Two Heaters No. X-1021		Two Heaters No. X-1022	
	GPM	Location	GPM	Location	GPM	Location	GPM	Location	GPM	Location	GPM	Location
LC-04	5.5	2	-	-	-	-	8.0	1 & 2	-	-	-	-
LC-05R	5.62	2	6.5	2	-	-	9.0	1 & 2	9.5	1 & 2	-	-
LC-05	5.75	2	7.0	2	-	-	10.0	1 & 2	10.5	1 & 2	-	-
LC-06	6.25	2	7.75	2	-	-	12.0	1 & 2	13.0	1 & 2	-	-
LC-07	6.5	2	8.5	2	13.0	2	13.0	1 & 2	15.5	1 & 2	15.5	1 & 2
LC-08	7.0	2	9.25	2	13.75	2	14.0	1 & 2	17.5	1 & 2	18.0	1 & 2
LC-09	7.25	2	10.0	2	14.5	2	14.5	1 & 2	20.0	1 & 2	20.0	1 & 2
LC-10	7.5	2	10.75	2	15.5	2	15.0	1 & 2	21.5	1 & 2	22.5	1 & 2
LC-11	8.0	2	11.50	2	16.5	2	16.0	1 & 2	23.5	1 & 2	24.5	1 & 2
LC-12	-	-	12.25	2	17.5	2	-	-	24.5	1 & 2	27.0	1 & 2
LCE-13	-	-	13	2	18.0	2	-	-	26	1 & 2	29	1 & 2
LCE-14	-	-	13	2	18.75	2	-	-	26	1 & 2	31.5	1 & 2
LCE-15	-	-	13	2	19.5	2	-	-	26	1 & 2	33.5	1 & 2
LCE-16	-	-	13	2	20	2	-	-	26	1 & 2	35.5	1 & 2
LCE-17	-	-	13	2	20	2	-	-	26	1 & 2	37.5	1 & 2
LCE-18	-	-	13	2	20	2	-	-	26	1 & 2	39.5	1 & 2
LCE-19	-	-	13	2	20	2	-	-	26	1 & 2	40	1 & 2
LCE-20	-	-	13	2	20	2	-	-	26	1 & 2	40	1 & 2
LCE-21	-	-	13	2	20	2	-	-	26	1 & 2	40	1 & 2
LCE-22	-	-	13	2	20	2	-	-	26	1 & 2	40	1 & 2
LCE-23	-	-	13	2	20	2	-	-	26	1 & 2	40	1 & 2
LCE-24	-	-	13	2	20	2	-	-	26	1 & 2	40	1 & 2

Above heater ratings are based on intermittent demand for water from 40°F to 140°F with 200°F boiler water.

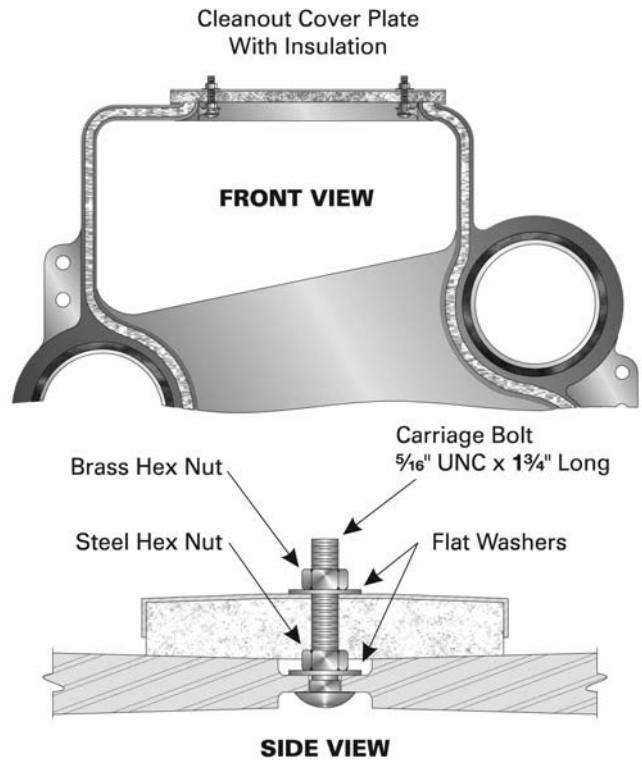
**DANGER:** Install mixing valve in hot water supply piping. Water temperature over 125°F can cause severe burns instantly or death from scalds.

**F. APPLY CLEANOUT COVER PLATES**

1. Apply the Cleanout Cover Plates on the tops of the section joints as shown in Figure 2.11.
2. Pre-assemble a steel flat washer and steel nut on the carriage bolts. Place a carriage bolt into each side of the cleanout opening as shown in the figure.
3. Tighten the lower nut securely.
4. Press the Cleanout Plate with insulation over the protruding carriage bolts until the insulation lays flush against the cast iron.
5. Apply a flat washer and brass nut to the carriage bolt. Draw the brass nuts down until the insulation presses firmly against the iron.

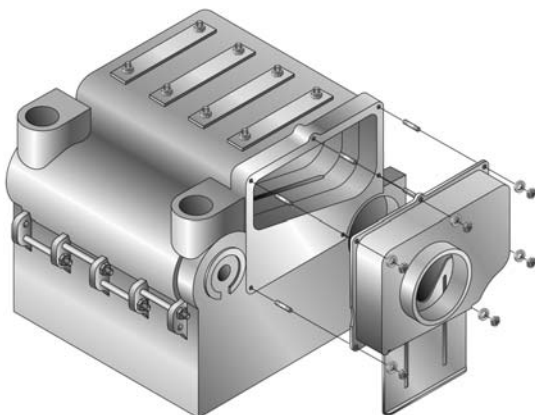
**G. INSTALL FLUE COLLAR**

1. (LC) Remove the Flue Collar and Rear Observation Door Assembly from the LC Rear Flue Box Carton. (LCE) Remove the Top Flue Outlet Plate, the Rear Flue Cover Plate and the Rear Observation Door Assembly from the LCE Top Flue Outlet Carton.
2. (LC) Attach the Flue Collar to the Back Section with 5/16" x 1-1/2" studs, flat washers and hex nuts supplied. See Figure 2.12. (LCE) Attach the Rear Flue Cover Plate to the Rear Section with 5/16" x 1-1/2" studs, flat washers and nuts supplied.
3. (LCE) Apply spray adhesive (supplied in Section Assembly Kits) to the rope groove on the bottom of the Top Flue Outlet Plate. Place the high temperature rope seal in the groove, overlapping at the ends for a good seal.
  - a) Place the plate over the opening provided by the three top flue intermediate sections at the front of the boiler. NOTE: Top flue outlet plate is marked "FRONT▼" for proper orientation.
  - b) Secure the plate and compress using the 3/8" tie down assembly, nuts and washers provided. See Figure 2.13.

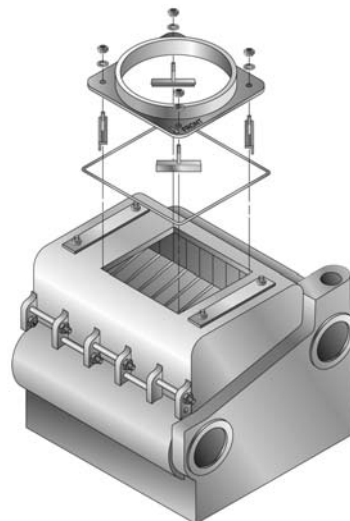


**Figure 2.11: Install Cleanout Cover Plates**

- c) Inspect the finished seal, particularly where the plate crosses the section joints.
- d) The correct Top Flue Outlet Plate for the LCE boiler is:
  - LCE-13 thru LCE-17 use the 14" flue opening, part number LCE-5007, Carton D
  - LCE-18 thru LCE-24 use the 16" flue opening, part number LCE-5007-1, Carton E
4. Attach the Rear Observation Door to the Rear Section with four (4) 5/16"-18 x 3/4" hex head bolts provided.



**Figure 2.12: Rear Flue Collar Attachment**



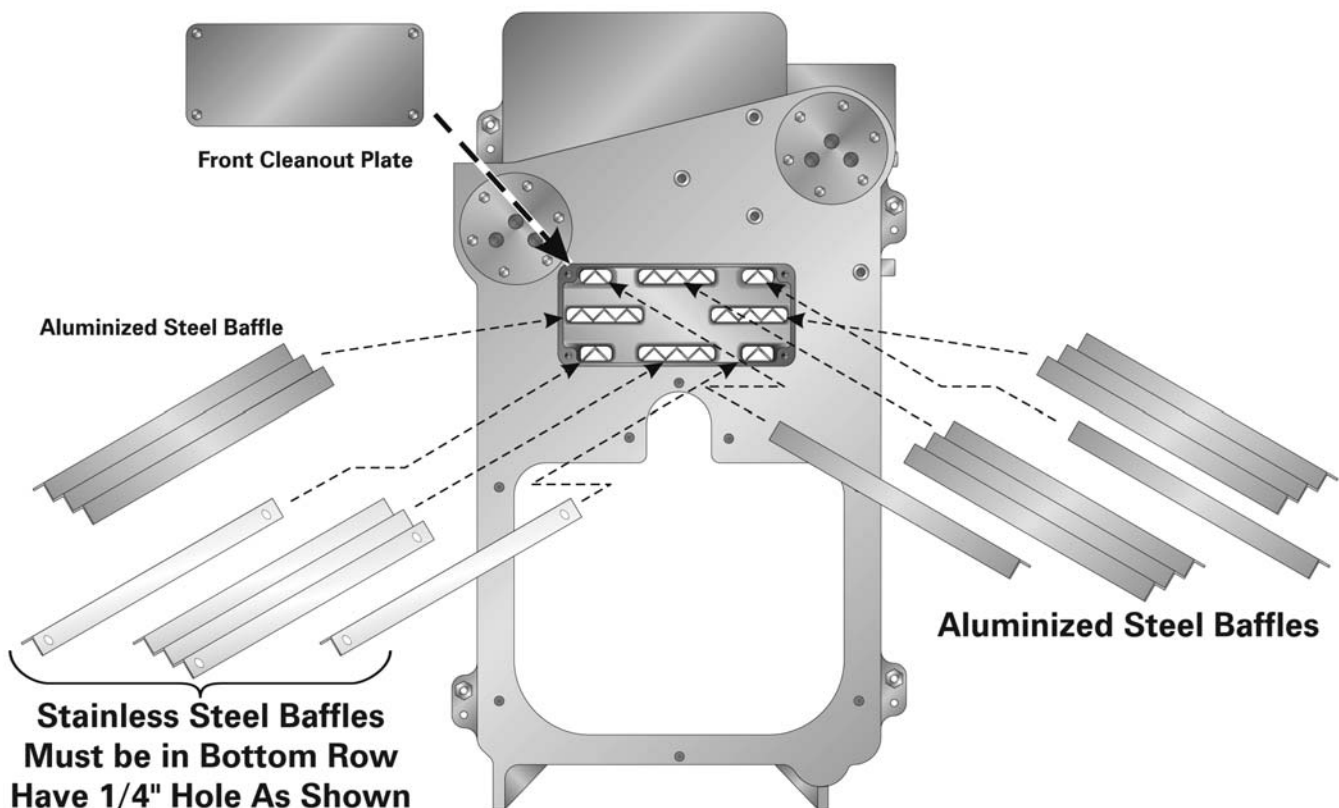
**Figure 2.13: Top Flue Collar Attachment**

**H. INSTALL FLUE BAFFLES**

1. Remove the Front Cleanout Plate from Front Section.
2. Open Baffles carton. Remove Baffles. For LC Only – Save Ceramic Fiber Liner for Section I. Save Rating Label for Chapter 4. Models LCE-13 through LCE-20 do not require baffles.
3. Place baffles as shown in Figure 2.14. Three of these are special stainless steel baffles, identified with a 1/4" hole punched in each end. These baffles must be placed in the lowest row of tubes.
4. Install the Front Cleanout Plate.

**I. INSTALL CHAMBER LINER**

1. (LCE) Remove Ceramic Fiber Liner from Jacket Carton E. Place the liner on the floor of the combustion chamber. Place the front end of the liner flush with the inside of the Front Section. The liner is 24 inches wide. It will not extend all the way to the rear of the boiler on all boiler sizes. No adhesive is required, just press the liner down firmly.



**Figure 2.14: Flue Baffle Locations**

## 3. PIPE THE BOILER

### A. PREPARATION

1. Make sure the boiler has been pressure tested as outlined in “Place the Boiler Sections” in this manual.
2. The Supply and Return piping can be installed before installing the jacket. Use nipples long enough to extend through the jacket.
3. Install a pipe plug or nipple and cap in the 3” tapping in the top of the tapped intermediate section when necessary. Use only the lower side connection, required for return piping as shown.

### B. SUPPLY AND RETURN PIPING

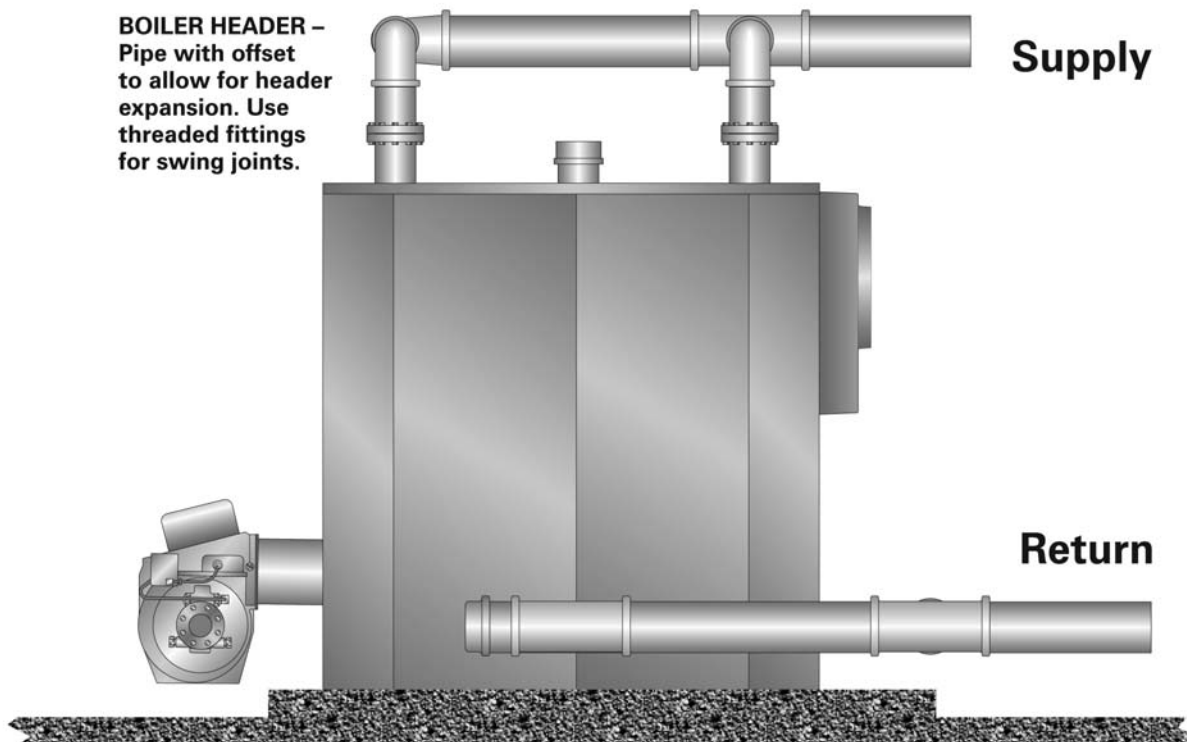
1. Always locate the Supply and Return connections as shown in Figure 3.1 and other illustrations in this manual.
2. The suggested supply and return sizing in Table 3.1 and in the “Boiler Ratings and Dimensions” section in this manual is based on a flow rate through the boiler equivalent to a 20°F temperature rise (1 gpm flow for each 10,000 Btu/Hr of boiler output). Using higher flow rates is not recommended. This could cause poor water flow distribution in the boiler.

Lower flow rates (higher temperature rise) are acceptable provided the return temperature to the boiler is at least 130°F on gas boilers and 150°F on oil boilers to prevent condensation of flue gases.

3. Do not reduce the number or size of supply and return connections given in Table 3.1. These are required to control the flow velocities in the boiler and maintain uniform distribution.
4. When the boiler is connected to heating coils located in air handling units, the boiler piping system must be equipped with flow control valves or other automatic devices to prevent gravity circulation of the boiler water during the cooling cycle.

### C. LOW SYSTEM TEMPERATURE

1. **Low Return Temperature Piping, General**
  - a) When the return temperature from the system will be below 130°F on gas boilers or 150°F on oil boilers for extended periods (heat pump systems, outdoor reset, snow melt, etc.), provide piping and controls to protect the boiler from condensation. Condensation will damage the boiler and will lead to shortened boiler life and maintenance problems.



**Figure 3.1: Piping Detail, Supply and Return Connections**

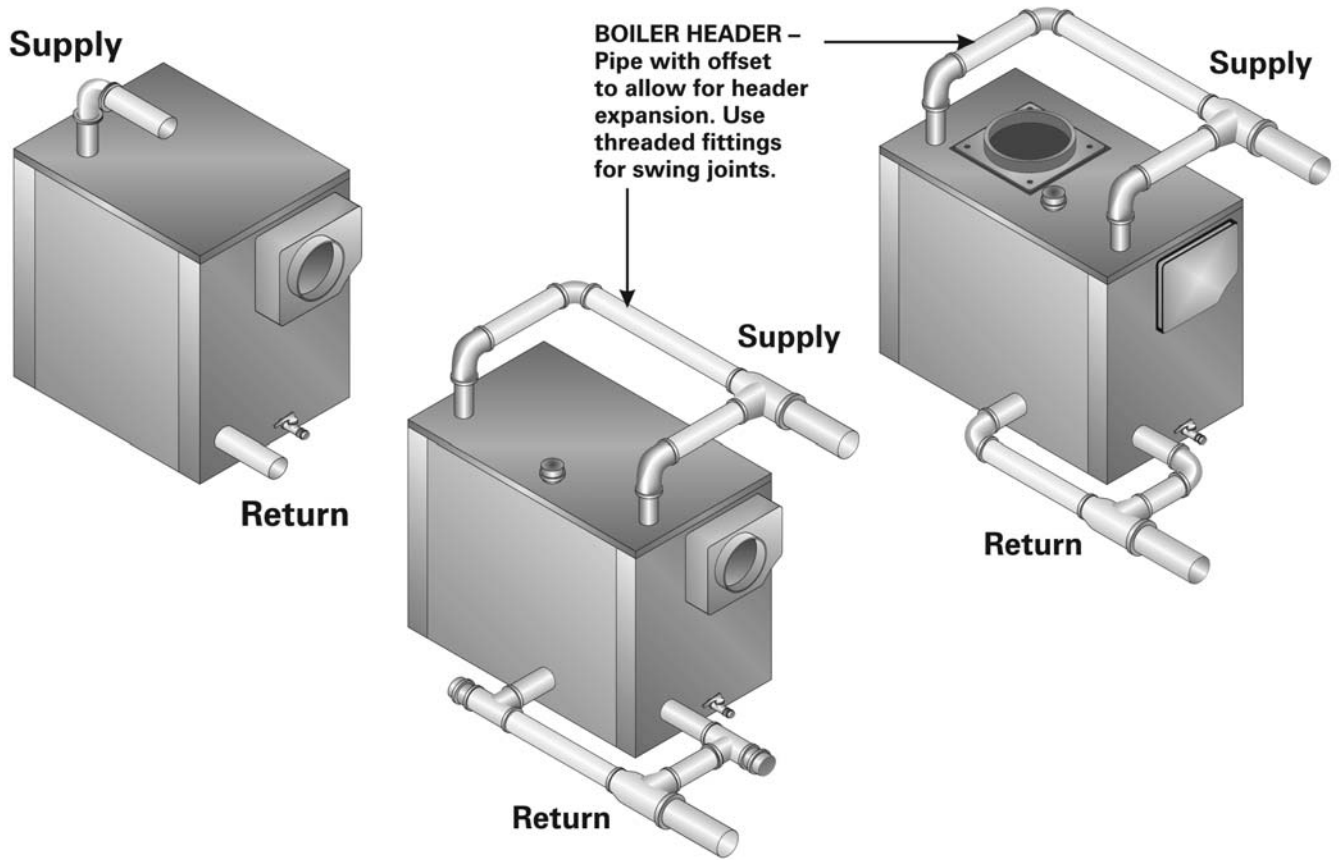


Figure 3.2: LC/LCE Boiler Piping

Table 3.1: Boiler Supply and Return Connections & Recommended Header Sizing

Model	I=B=R Gross Output MBH	GPM @ 20°F Rise	Suggested Supply Connections - Top			Return Connections Rear and Side		
			Number	Size (Inches)	Header (Inches)	Number	Size (Inches)	Header (Inches)
LC-04	547	55	1	2-1/2	2-1/2	1	2-1/2	2-1/2
LC-05R	649	65	1	2-1/2	2-1/2	1	2-1/2	2-1/2
LC-05	707	71	1	2-1/2	2-1/2	1	2-1/2	2-1/2
LC-06	868	87	1	3	3	1	3	3
LC-07	1029	103	1	3	3	1	3	3
LC-08	1189	119	2	3	3	2	3	3
LC-09	1350	135	2	3	3	2	3	3
LC-10	1511	151	2	4	4	2	3	4
LC-11	1672	167	2	4	4	2	3	4
LC-12	1832	183	2	4	4	2	3	4
LCE-13	1966	197	2	4	4	2	3	4
LCE-14	2125	213	2	4	4	2	3	4
LCE-15	2284	228	2	4	4	2	3	4
LCE-16	2444	244	2	4	4	2	3	4
LCE-17	2603	260	2	4	5	2	3	5
LCE-18	2763	276	2	4	5	2	3	5
LCE-19	2922	292	2	4	5	2	3	5
LCE-20	3082	308	2	4	5	2	3	5
LCE-21	3256	326	2	4	5	3	3	5
LCE-22	3430	343	2	4	5	3	3	5
LCE-23	3604	360	2	4	5	3	3	5
LCE-24	3777	378	2	4	5	3	3	5

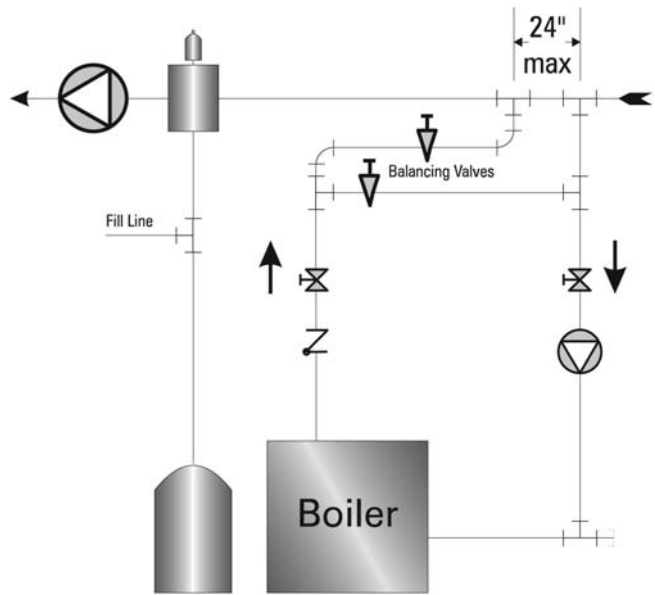
b) Temporary low temperature operation is acceptable within limits. For occasional cold start-ups condensation will occur, but will have limited effects. If the system is frequently allowed to cool to room temperature, such as on night set-back systems or energy management systems, cold start-ups will occur often. These systems require a Variable Low Temperature piping and control arrangement, described below.

**2. Constant Low Temperature**

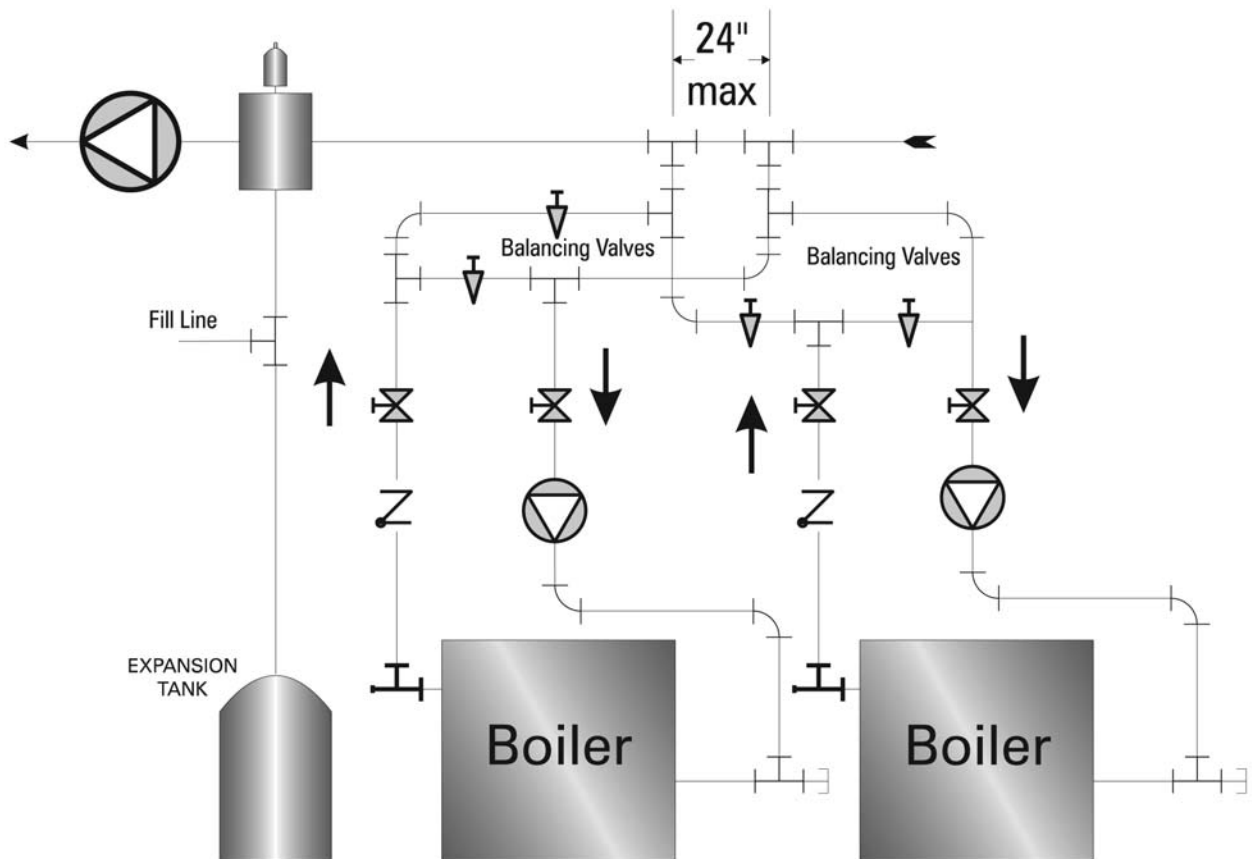
a) For systems with a relatively constant low operating temperature (such as heat pump systems), you can pipe a fixed flow by-pass arrangement as shown in Figure 3.3. This piping will not work for variable low temperature systems such as outdoor reset systems or primary/secondary systems with a large primary circuit temperature drop. See Figure 3.4 for multiple boilers.

**3. Variable Low Temperature**

a) When the return water temperature from the system will vary (outdoor reset, snow melt, etc.) a fixed bypass will not work. Fixed bypass piping works by setting a high temperature rise through the boiler. As the system return temperature rises (during primary heating months, for example) the boiler will cycle on the limit control frequently, causing poor performance and excessive cycling. To protect the boiler and provide proper operation, install a temperature



**Figure 3.3: Fixed By-Pass Piping, Single Boiler**



**Figure 3.4: Fixed By-Pass Piping, Multiple Boilers**



control valve and boiler circuit pump piped off of the system as a secondary loop. See Figure 3.6 for a single boiler and Figure 3.7 for multiple boilers.

**D. CHILLED WATER SYSTEMS**

1. If the boiler will be used in conjunction with a refrigeration system, the chilled medium must be placed in parallel with the boiler and proper valves applied to prevent the chilled medium from entering the boiler. See Figure 3.5.

**E. HIGH FLOW RATE PIPING**

1. For flow rates higher than given in Table 3.1, provide bypass piping around the boiler to limit the boiler flow to that given in the table or pipe the boiler in a secondary loop with its own pump as shown in Figure 3.3.

**F. MULTIPLE BOILER INSTALLATIONS**

1. For multiple boiler installations, piping the boilers in a secondary loop is recommended. Each boiler should be provided with its own pump and piped off of the secondary loop header. See Figure 3.7 for systems with return temperature above 130°F on gas boilers or 150°F on oil boilers. For low temperature systems, see Figure 3.4 (constant low temperature systems) or Figure 3.8 (variable low temperature systems).
2. You can use alternative piping if desired, such as parallel piping or series piping in the primary system loop. But these systems are less versatile.
  - a) With parallel piping, for instance, the system flow conditions change if one or more of the boiler shut-off valves are closed. It is difficult to pipe parallel boilers to protect the boiler from low return temperatures.
  - b) With series piping, temperature control to the system is difficult because the temperature rise equals the sum of the rises through each boiler. Series piped boilers cannot be isolated for servicing.

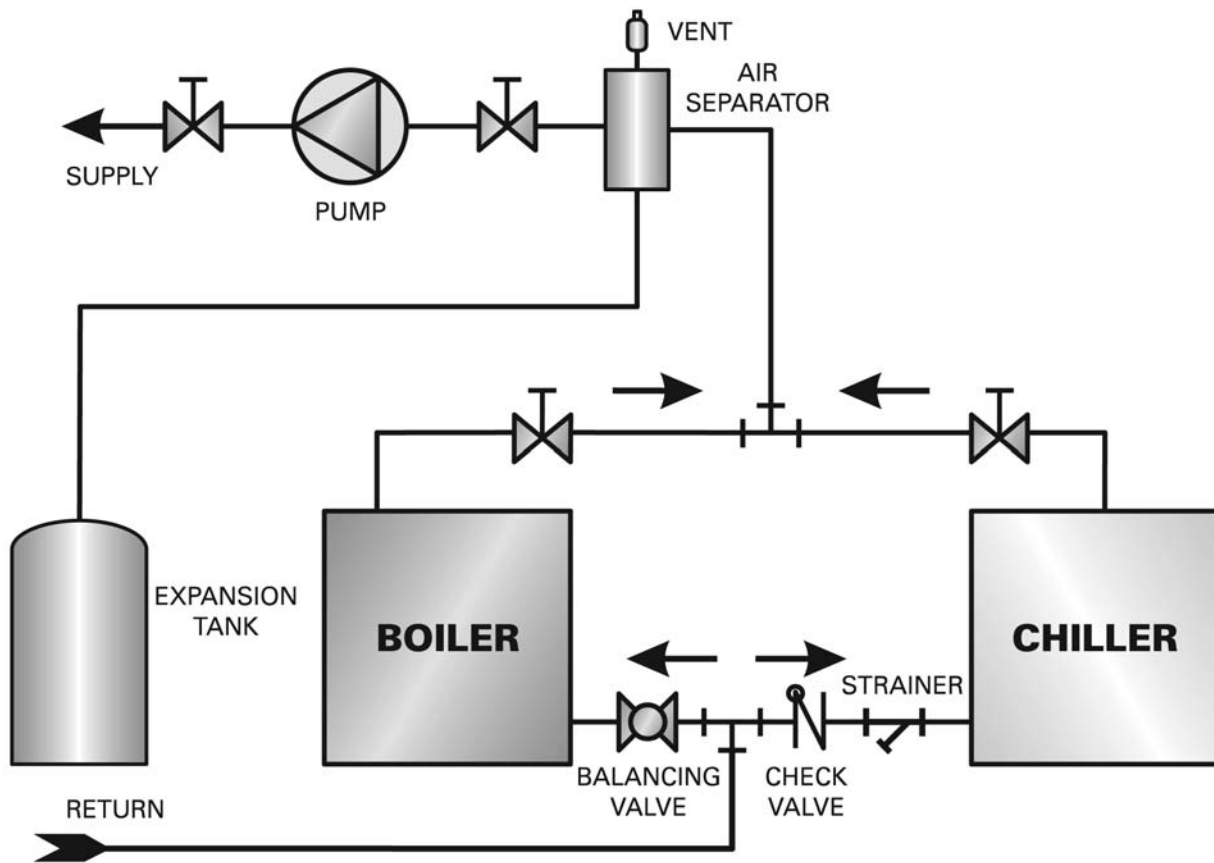
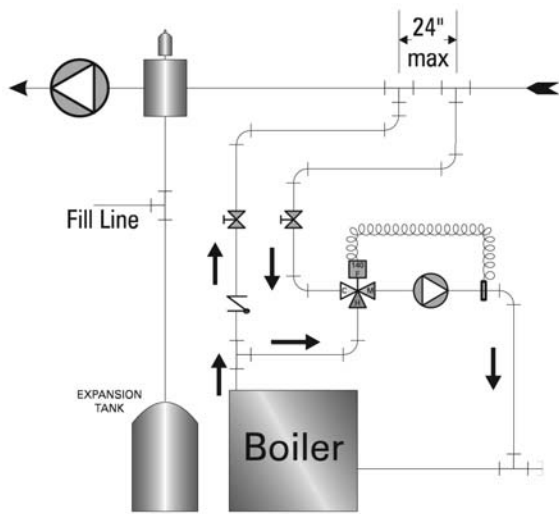
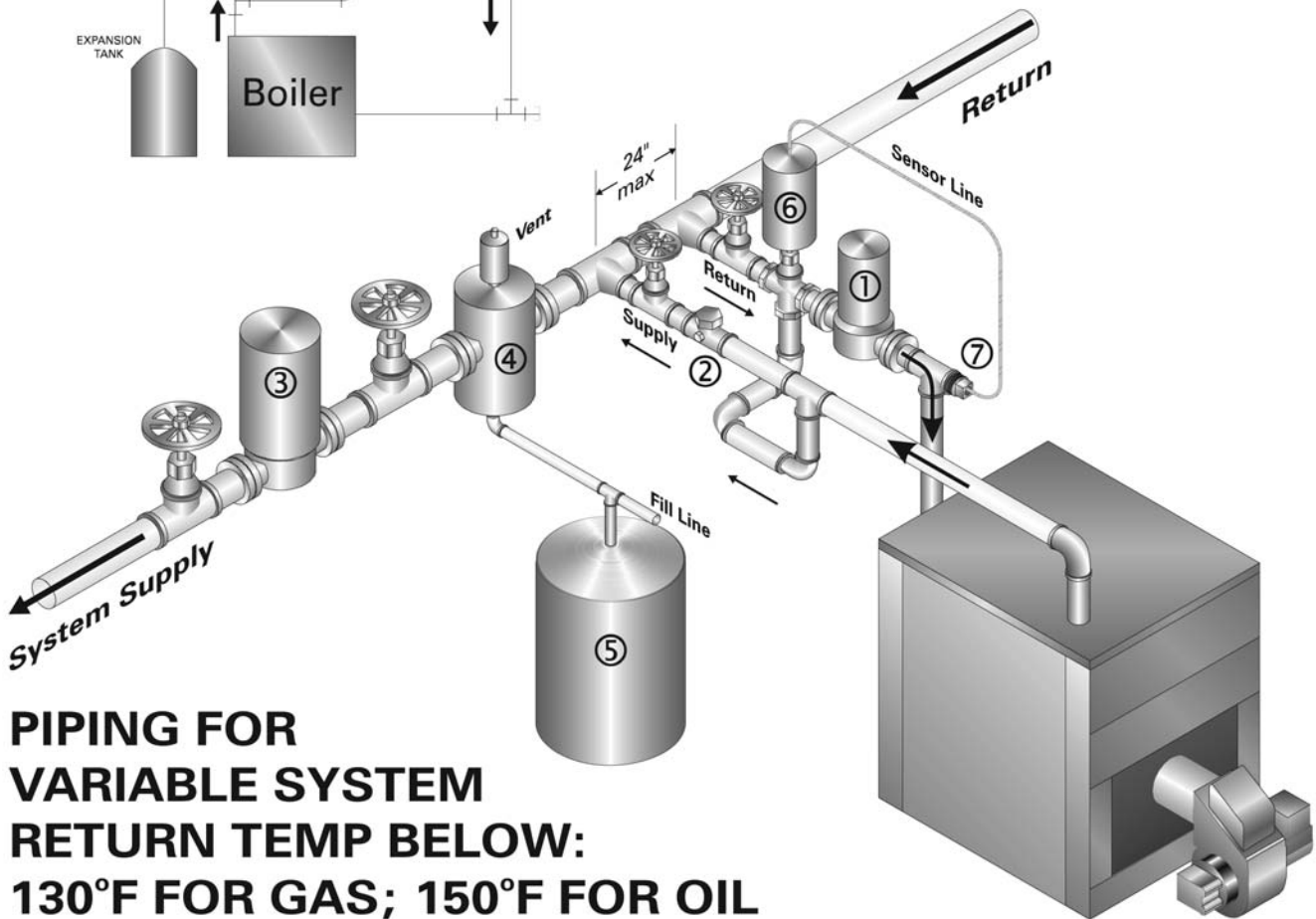


Figure 3.5: Piping to Isolate Boiler from Chilled Medium on Chiller Systems



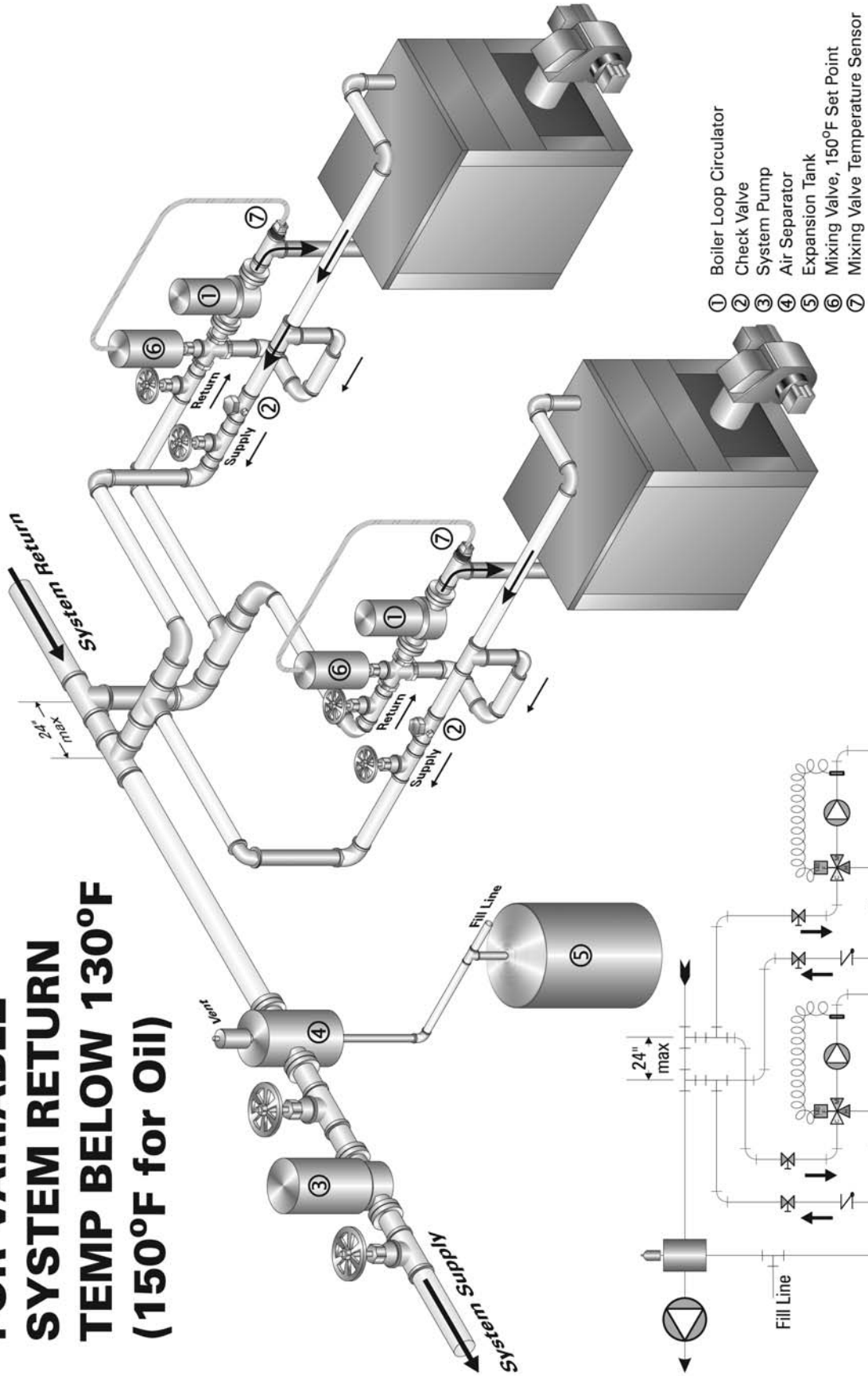
- ① Boiler Loop Circulator
- ② Check Valve
- ③ System Pump
- ④ Air Separator
- ⑤ Expansion Tank
- ⑥ Mixing Valve, 150°F Set Point
- ⑦ Mixing Valve Temperature Sensor



**PIPING FOR  
VARIABLE SYSTEM  
RETURN TEMP BELOW:  
130°F FOR GAS; 150°F FOR OIL**

**Figure 3.6: Piping for Variable Low Temperature Systems, Single Boiler**

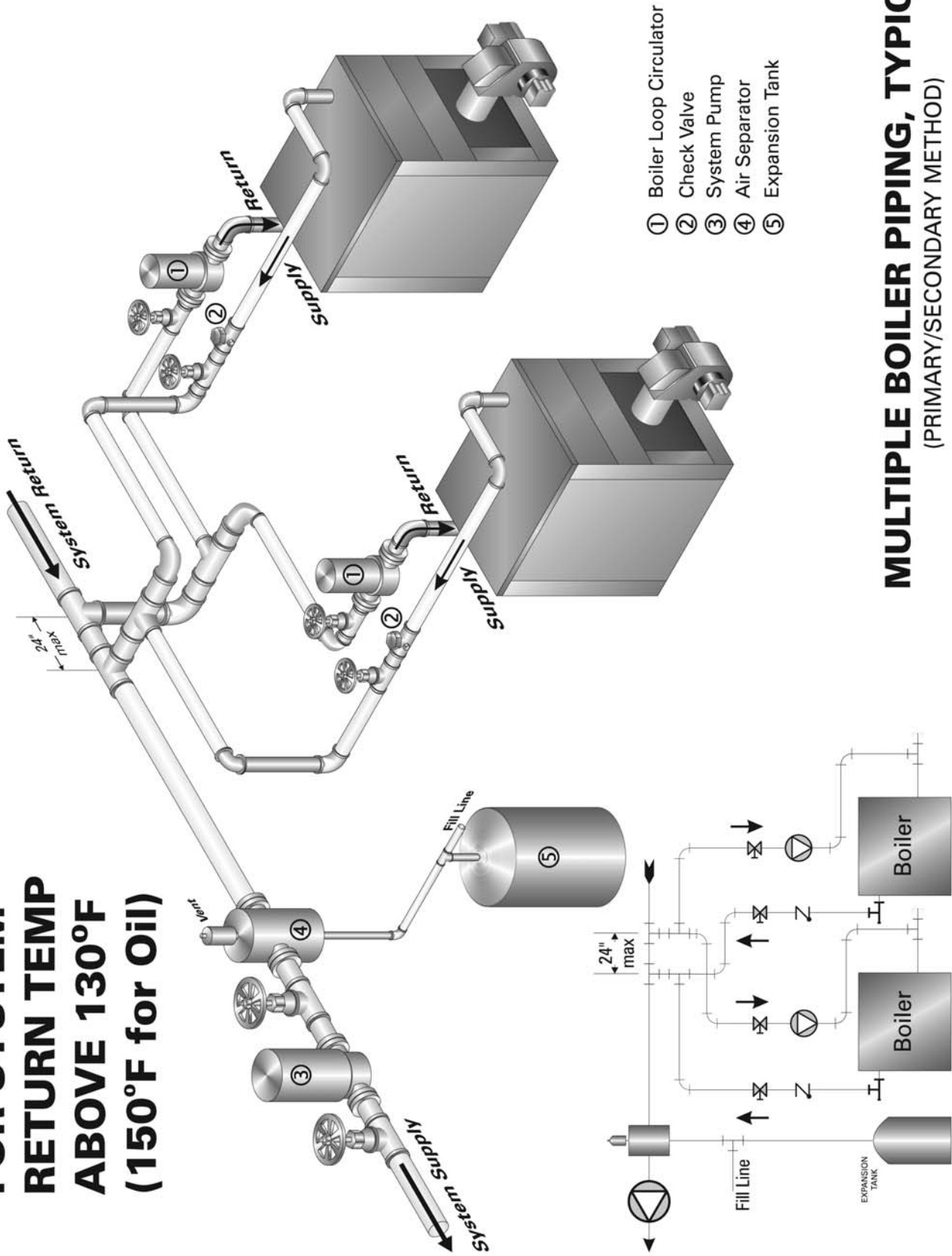
**FOR VARIABLE  
SYSTEM RETURN  
TEMP BELOW 130°F  
(150°F for Oil)**



**MULTIPLE BOILER PIPING, TYPICAL**  
(PRIMARY/SECONDARY METHOD, LOW TEMP RETURN)

Figure 3.7: Multiple Boiler Piping, System Return Temperature Above 130°F on Gas, 150°F on Oil

**FOR SYSTEM  
RETURN TEMP  
ABOVE 130°F  
(150°F for Oil)**



- ① Boiler Loop Circulator
- ② Check Valve
- ③ System Pump
- ④ Air Separator
- ⑤ Expansion Tank

**MULTIPLE BOILER PIPING, TYPICAL**  
(PRIMARY/SECONDARY METHOD)

Figure 3.8: Piping for Variable Low Temperature Systems, Multiple Boilers

# 4. ASSEMBLE THE JACKET

## A. PREPARE THE PARTS

1. Collect all the jacket cartons: **Jacket Front & Back Carton plus Jacket Side & Top Cartons**. See the Shipping List in the front of this manual for the jacket cartons required. The cartons contain the jacket parts and screws. The jacket panels are pre-insulated.
2. Remove all needed knockouts from the jacket parts before beginning assembly.

## B. APPLY JACKET SIDES AND CORNERS

1. See Figure 4.2 for details.
2. The Side Panels can be used on either side of the boiler.
3. Place the Jacket Side Panels on each side leaned against the Boiler Sections.
4. On Models LC-08 through LC-12, each side uses two panels. Place the panels so the seam is centered on the Tapped Intermediate Section. On LCE models, place panels in the sequence shown in Table 4.1.
5. On boilers with two or more Jacket Side Panels per side, join the panels together with #10 x 1/2" sheet metal screws. Also attach the Jacket Side Panel Reinforcing Angle inside the jacket at the bottom of the seam.
6. Attach the Left Front Corner Panel to the Left Side Panel with #10 x 1/2" sheet metal screws.
7. Attach the Right Front Corner Panel to the Right Side Panel with #10 x 1/2" sheet metal screws.

## C. APPLY JACKET FRONT PANELS

1. Attach the Upper Front Panel to the Right and Left Front Corner Panels with #10 x 1/2" sheet metal screws.

2. Attach the Middle Front Panel and Lower Front Rail in the same manner.
3. Position the Jacket Assembly with the front panels pushed up against the front section. You will need the jacket in this position to install the Burner Front Plate.

## D. APPLY JACKET REAR PANEL

1. Attach the Rear Jacket Panel to the Jacket Side Panels with #10 x 1/2" sheet metal screws.

## E. APPLY JACKET TOP PANELS

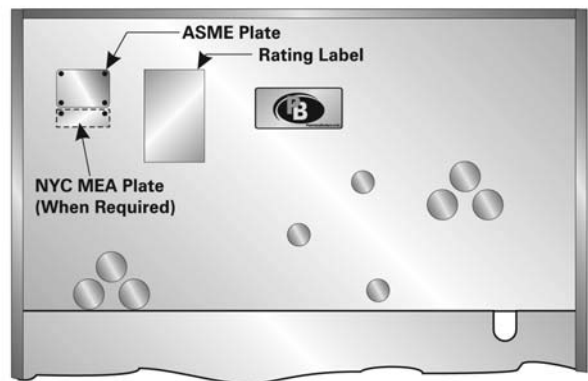
1. Attach the Top Front Panel to the Sides and Upper Front Panel with #10 x 1/2" sheet metal screws.
2. Models LC-08 through LC-12 use two Jacket Top Panels. Place them on top with the seam at the same point as the side panels. Join them at their seam with #10 x 1/2" sheet metal screws. On LCE models, place panels in the sequence shown in Table 4.1.
3. Attach the Jacket Top Panel to the Jacket Top Front Panel with #10 x 1/2" sheet metal screws.
4. Attach the Top Rear Panel to the Jacket Top Panel with #10 x 1/2" sheet metal screws.
5. Finish by placing #10 x 1/2" sheet metal screws in the remaining holes along the Jacket Top Panel flanges, into the Jacket Side Panels.

## F. APPLY PLATES AND LABELS

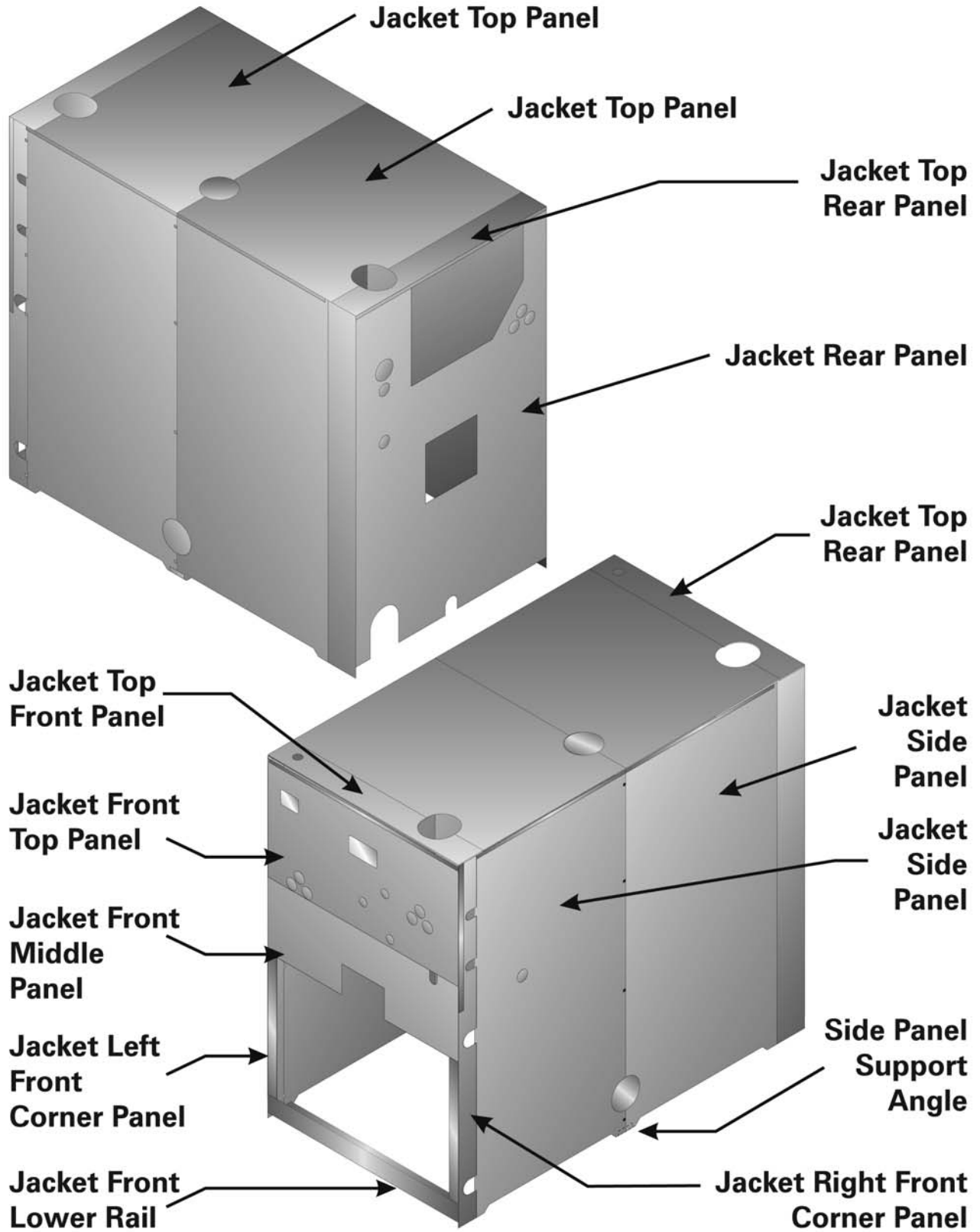
1. Mount Boiler Rating Plates and Agency Plates on the Upper Jacket Front Panel as shown in Figure 4.1.
2. Secure metal plates with #6 x 1/4" sheet metal screws. Apply all adhesive-backed labels.

**Table 4.1: Jacket Top & Side Panel Placement**

Model	Locate Jacket Top and Side Panels in the Position Below (Numbers are from Rear to Front)				
	5 (Front)	4	3	2	1 (Rear)
LCE-13	-	-	E	B	A
LCE-14	-	-	E	B	B
LCE-15	-	-	E	B	C
LCE-16	-	-	E	C	C
LCE-17	-	E	A	B	B
LCE-18	-	E	B	B	B
LCE-19	-	E	C	B	B
LCE-20	E	A	A	B	B
LCE-21	E	A	B	B	B
LCE-22	E	B	B	B	B
LCE-23	E	B	B	B	C
LCE-24	E	C	B	B	C



**Figure 4.1: Location of Rating, Agency and Instruction Plates on Jacket Front Top Panel**



**Figure 4.2: Jacket Assembly**

## 5. VENTING

Refer to Chapter 1, Preinstallation, Section D. Chimney or Vent for installation requirements. Refer to Chapter 9, Starting the Boiler, Section C. Run Burner Check Out for damper settings and draft requirements.

## 6. INSTALL THE BURNER

### A. BURNER APPLICATION

1. Refer to Burner Spec and Data Sheets for the Oil and Gas/Oil Burners pre-tested with Series LC boilers.
2. Make sure the nozzle sizing and spray pattern match those given in the spec and data sheets.
3. See Figure 6.1 and Table 6.1 for combustion chamber dimensions.

### B. INSTALL BURNER MOUNTING PLATE

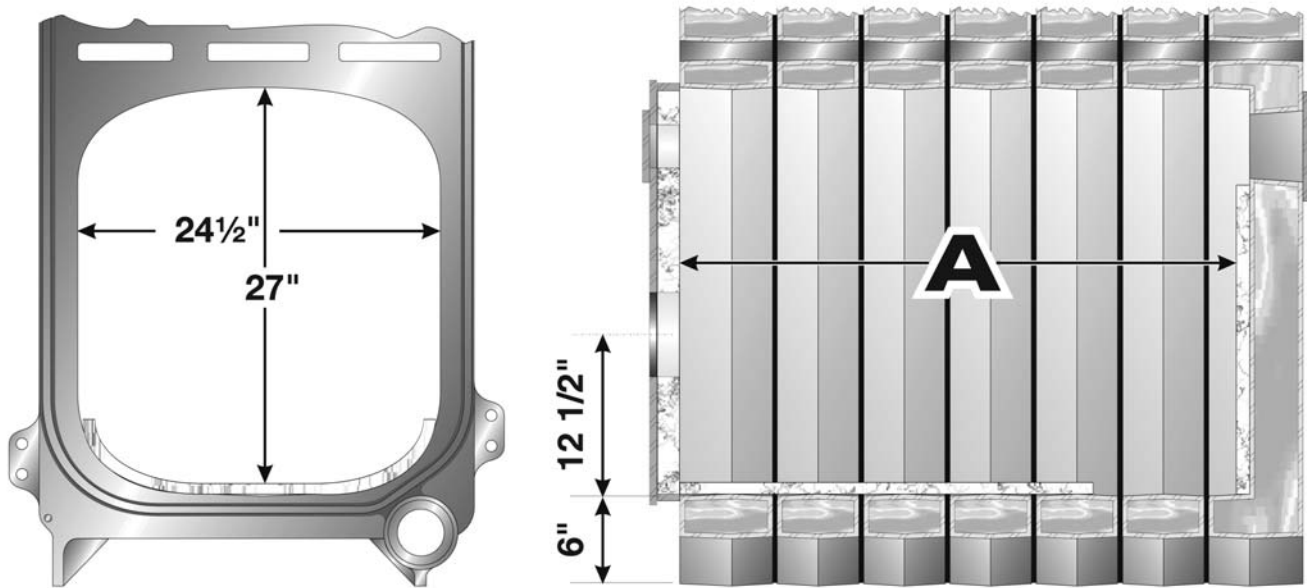
1. The Burner Mounting Plate is made to fit the burner being used. Burners vary in bolt pattern for the flange, burner tube diameter, insertion length and near-tube configuration. Make sure the front plate is correct for your burner if purchased separately from the boiler.
2. Remove the Burner Mounting Plate and Hardware Bag from the crate.

3. Screw (7) 3/8"-16 x 2 1/4" studs into the holes in the front section around the chamber opening.
4. Secure the Burner Mounting Plate to the front section with the flat washers and hex nuts.

### C. MOUNT THE BURNER

1. Remove the Burner from its crate. Read the burner instructions.
2. Insert (4) 3/8"-16 x 1 1/4" studs supplied with Burner Mounting Plate into the front plate holes.
3. Place the high temperature gasket on the burner front plate and secure the burner to the front plate with 3/8" flat washers and hex nuts.
4. If the burner is supplied with a pedestal, install it to the burner per the Burner Manufacturer's Instructions. The pedestal provides additional support and prevents the burner from sagging.

## INSTALL THE BURNER



**Figure 6.1: Combustion Chamber Layout – See Table 6.1 for Dimensions**

**Table 6.1: Combustion Chamber Dimensions**

Model	Chamber Length "A" (Inches)	Burner Front Plate Extension Past Jacket (Inches)				
		Beckett	Carlin	Gordon- Piatt	Power Flame	Webster
LC-04	18 <sup>7</sup> / <sub>8</sub>	6 <sup>1</sup> / <sub>8</sub>	6 <sup>1</sup> / <sub>8</sub>	6 <sup>1</sup> / <sub>8</sub>	6 <sup>1</sup> / <sub>8</sub>	6 <sup>1</sup> / <sub>8</sub>
LC-05R	23 <sup>15</sup> / <sub>16</sub>	6 <sup>1</sup> / <sub>8</sub>	6 <sup>1</sup> / <sub>8</sub>	1 <sup>1</sup> / <sub>8</sub>	6 <sup>1</sup> / <sub>8</sub>	6 <sup>1</sup> / <sub>8</sub>
LC-05	23 <sup>15</sup> / <sub>16</sub>	6 <sup>1</sup> / <sub>8</sub>	6 <sup>1</sup> / <sub>8</sub>	1 <sup>1</sup> / <sub>8</sub>	6 <sup>1</sup> / <sub>8</sub>	6 <sup>1</sup> / <sub>8</sub>
LC-06	29	6 <sup>1</sup> / <sub>8</sub>	6 <sup>1</sup> / <sub>8</sub>	1 <sup>1</sup> / <sub>8</sub>	6 <sup>1</sup> / <sub>8</sub>	6 <sup>1</sup> / <sub>8</sub>
LC-07	34 <sup>1</sup> / <sub>16</sub>	6 <sup>1</sup> / <sub>8</sub>	6 <sup>1</sup> / <sub>8</sub>	1 <sup>1</sup> / <sub>8</sub>	6 <sup>1</sup> / <sub>8</sub>	6 <sup>1</sup> / <sub>8</sub>
LC-08	39 <sup>7</sup> / <sub>8</sub>	1 <sup>1</sup> / <sub>8</sub>	6 <sup>1</sup> / <sub>8</sub>	1 <sup>1</sup> / <sub>8</sub>	1 <sup>1</sup> / <sub>8</sub>	1 <sup>1</sup> / <sub>8</sub>
LC-09	44 <sup>3</sup> / <sub>16</sub>	1 <sup>1</sup> / <sub>8</sub>	1 <sup>1</sup> / <sub>8</sub>	1 <sup>1</sup> / <sub>8</sub>	1 <sup>1</sup> / <sub>8</sub>	1 <sup>1</sup> / <sub>8</sub>
LC-10	49 <sup>1</sup> / <sub>4</sub>	1 <sup>1</sup> / <sub>8</sub>	1 <sup>1</sup> / <sub>8</sub>	1 <sup>1</sup> / <sub>8</sub>	1 <sup>1</sup> / <sub>8</sub>	1 <sup>1</sup> / <sub>8</sub>
LC-11	54 <sup>3</sup> / <sub>16</sub>	1 <sup>1</sup> / <sub>8</sub>	1 <sup>1</sup> / <sub>8</sub>	1 <sup>1</sup> / <sub>8</sub>	1 <sup>1</sup> / <sub>8</sub>	1 <sup>1</sup> / <sub>8</sub>
LC-12	59 <sup>3</sup> / <sub>8</sub>	1 <sup>1</sup> / <sub>8</sub>	1 <sup>1</sup> / <sub>8</sub>	1 <sup>1</sup> / <sub>8</sub>	1 <sup>1</sup> / <sub>8</sub>	1 <sup>1</sup> / <sub>8</sub>
LCE-13	64 <sup>7</sup> / <sub>16</sub>	1 <sup>1</sup> / <sub>8</sub>	1 <sup>1</sup> / <sub>8</sub>	1 <sup>1</sup> / <sub>8</sub>	1 <sup>1</sup> / <sub>8</sub>	1 <sup>1</sup> / <sub>8</sub>
LCE-14	69 <sup>1</sup> / <sub>2</sub>	1 <sup>1</sup> / <sub>8</sub>	1 <sup>1</sup> / <sub>8</sub>	1 <sup>1</sup> / <sub>8</sub>	1 <sup>1</sup> / <sub>8</sub>	1 <sup>1</sup> / <sub>8</sub>
LCE-15	74 <sup>9</sup> / <sub>16</sub>	1 <sup>1</sup> / <sub>8</sub>	1 <sup>1</sup> / <sub>8</sub>	1 <sup>1</sup> / <sub>8</sub>	1 <sup>1</sup> / <sub>8</sub>	1 <sup>1</sup> / <sub>8</sub>
LCE-16	79 <sup>5</sup> / <sub>8</sub>	1 <sup>1</sup> / <sub>8</sub>	1 <sup>1</sup> / <sub>8</sub>	1 <sup>1</sup> / <sub>8</sub>	1 <sup>1</sup> / <sub>8</sub>	1 <sup>1</sup> / <sub>8</sub>
LCE-17	84 <sup>11</sup> / <sub>16</sub>	1 <sup>1</sup> / <sub>8</sub>	1 <sup>1</sup> / <sub>8</sub>	1 <sup>1</sup> / <sub>8</sub>	1 <sup>1</sup> / <sub>8</sub>	1 <sup>1</sup> / <sub>8</sub>
LCE-18	89 <sup>3</sup> / <sub>4</sub>	1 <sup>1</sup> / <sub>8</sub>	1 <sup>1</sup> / <sub>8</sub>	1 <sup>1</sup> / <sub>8</sub>	1 <sup>1</sup> / <sub>8</sub>	1 <sup>1</sup> / <sub>8</sub>
LCE-19	94 <sup>13</sup> / <sub>16</sub>	1 <sup>1</sup> / <sub>8</sub>	1 <sup>1</sup> / <sub>8</sub>	1 <sup>1</sup> / <sub>8</sub>	1 <sup>1</sup> / <sub>8</sub>	1 <sup>1</sup> / <sub>8</sub>
LCE-20	99 <sup>7</sup> / <sub>8</sub>	1 <sup>1</sup> / <sub>8</sub>	1 <sup>1</sup> / <sub>8</sub>	1 <sup>1</sup> / <sub>8</sub>	1 <sup>1</sup> / <sub>8</sub>	1 <sup>1</sup> / <sub>8</sub>
LCE-21	104 <sup>15</sup> / <sub>16</sub>	1 <sup>1</sup> / <sub>8</sub>	1 <sup>1</sup> / <sub>8</sub>	1 <sup>1</sup> / <sub>8</sub>	1 <sup>1</sup> / <sub>8</sub>	1 <sup>1</sup> / <sub>8</sub>
LCE-22	110	1 <sup>1</sup> / <sub>8</sub>	1 <sup>1</sup> / <sub>8</sub>	1 <sup>1</sup> / <sub>8</sub>	1 <sup>1</sup> / <sub>8</sub>	1 <sup>1</sup> / <sub>8</sub>
LCE-23	115 <sup>1</sup> / <sub>16</sub>	N/A	1 <sup>1</sup> / <sub>8</sub>	1 <sup>1</sup> / <sub>8</sub>	1 <sup>1</sup> / <sub>8</sub>	1 <sup>1</sup> / <sub>8</sub>
LCE-24	120 <sup>7</sup> / <sub>8</sub>	N/A	N/A	1 <sup>1</sup> / <sub>8</sub>	1 <sup>1</sup> / <sub>8</sub>	1 <sup>1</sup> / <sub>8</sub>



# 7. CONNECT FUEL PIPING

## A. GENERAL

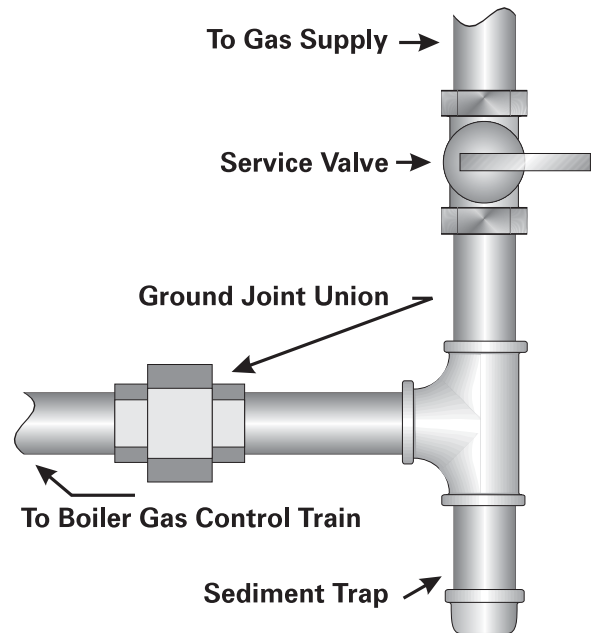
1. Read the Burner Instruction Manual, supplied with the boiler or with the burner if purchased separately. Review applicable code requirements for burner and fuel piping installations.
2. Install piping to allow removal of burner and access to combustion chamber for cleaning or service.

## B. INSTALL FUEL OIL PIPING

1. Place the fuel oil tank and install the piping in accordance with NFPA-31 and all other applicable codes.
2. General Guidelines for Oil Piping
  - a) Follow the guidelines in the Burner Manual for sizing oil lines. Never use smaller than 1/2" OD copper tubing.
  - b) Install manual shut-off valves on the suction line at the burner and at the oil line entrance to the building. If installing a shut-off valve on the return line, you must provide an oil pressure relief valve piped ahead of the shut-off valve and discharged to the tank to prevent over-pressure conditions.
  - c) Install a two-pipe oil distribution system when possible. It will improve the reliability of the oil delivery to the burner.
  - d) Use flare fittings when using copper tubing.
  - e) Provide an oil line filter in the suction line. Size the filter for the suction gear capacity of the burner oil pump if running a two-pipe system.
  - f) If burner is above the top of the fuel oil tank, install a check valve on the oil suction line at the burner to prevent oil from evacuating the line. If burner is below the top of the tank, install an anti-siphon device to prevent oil flow should the oil line break.

## C. INSTALL GAS SUPPLY PIPING

1. Size the piping as required by the National Fuel Gas Code, ANSI Z223.1 or as required by local codes.
  - a) Use Table 7.1 for sizing of natural gas for a system pressure drop of 0.3 inch water column.
2. The standard gas train is designed for a maximum pressure of 1/2 psig (14 inches water column). Make sure the system regulator will not allow a higher pressure to the Gas Control Train under any conditions.
3. The minimum gas supply pressure is listed on the Burner Rating Plate. Make sure the system regulator and the piping are sized and adjusted properly to provide this pressure under all conditions.



**Figure 7.1: Gas Supply Connection to Boiler**

4. Install a Service Valve, Sediment Trap and Ground Joint Union at the supply connection to the Gas Control Train as shown in Figure 7.1. These are not supplied with the boiler. Install them in accordance with local codes.
5. Use only pipe joint compounds rated for use with Liquefied Petroleum Gases.

## D. TEST GAS SUPPLY PIPING

1. ISOLATE THE BOILER GAS CONTROL TRAIN FROM THE SYSTEM DURING TEST:
  - a) Test pressure 1/2 psig or less – Close the Manual Shut-Off Valve on the Boiler Gas Control Train.
  - b) Test pressure over 1/2 psig – Disconnect the gas supply piping upstream of the Boiler Manual Shut-Off Valve.

### **⚠ WARNING**

**Do not expose the Gas Control Train to excessive pressure. The gas valves can be damaged. This could result in explosion hazard and severe personal injury or death.**

**Do not test gas supply piping with open flame. Use a soap suds mixture brushed onto the pipe joints to test for leaks.**

## CONNECT FUEL PIPING

**Table 7.1: Capacity of Gas Supply Pipe in Cubic Feet Per Hour of Natural Gas for Pressure Drop of 0.3 inch Water Column.**

Pipe Length (Feet)	1-1/4" Pipe	1-1/2" Pipe	2" Pipe	2-1/2" Pipe	3" Pipe	4" Pipe	6" Pipe
10	1050	1600	3050	4800	8500	17500	44000
20	730	1100	2100	3300	5900	12000	31000
30	590	890	1650	2700	4700	9700	25000
40	500	760	1450	2300	4100	8300	22000
50	440	670	1270	2000	3600	7400	20000
60	400	610	1150	1850	3250	6800	18000
70	350	560	1050	1700	3000	6200	17000
90	320	490	930	1500	2600	5400	15000
100	305	460	870	1400	2500	5100	14000
150	250	380	710	1130	2000	4100	11500

Above ratings based on natural gas with specific gravity of 0.60 allowing pressure drop of 0.3 inches water column. No allowance is needed for pipe fittings. Use the following multipliers on above capacities for specific gravity other than 0.60:

<b>Specific Gravity</b>	0.50	0.55	0.60	0.65	0.70
<b>Multiply Capacity by:</b>	1.10	1.04	1.00	0.962	0.926

# 8. INSTALL CONTROLS AND TRIM

## A. INSTALL SAFETY RELIEF VALVE

1. Pipe the Safety Relief Valve off of the 2-1/2" tapping at the upper left side of the Rear Section. Make sure the relief valve sizing meets local code requirements. See Figure 8.1.



### CAUTION

Pipe the discharge of the Safety Relief Valve(s) away from any traffic area, preferably to a floor drain. This is necessary to prevent injury should the valve discharge.

Pipe the discharge full size of valve outlet.

## B. INSTALL DRAIN VALVE

1. Install a 3/4" drain valve in the lower center tapping in the Rear Section. See Figure 8.1 and Figure 8.2.
2. Pipe the valve discharge to a floor drain if available or apply a nipple and cap to close off when not in use.

## C. INSTALL LOW WATER CUTOFFS

1. See Figure 8.2 for the locations of tappings for probe type and float type low water cutoffs. The Front Section has a 3/4" tapping for a probe type control. The Rear Section has two 1" tappings for mounting a float type control.

## D. INSTALL CONTROLS & TRIM

1. Install the Temperature-Pressure Gage in the 1/2" tapping at the upper center of the Front Section. See Figure 8.2.
2. Mount the Operating Temperature Limit Control bulb well in the Coil Cover Plate at the upper right of the Front Section. Place the well in the right side 3/4" control tapping of the cover plate if a Tankless Heater is not installed there. If a tankless heater is installed at this location (Position 2), mount the well in the center 3/4" control tapping of the coil. See Figure 8.2.

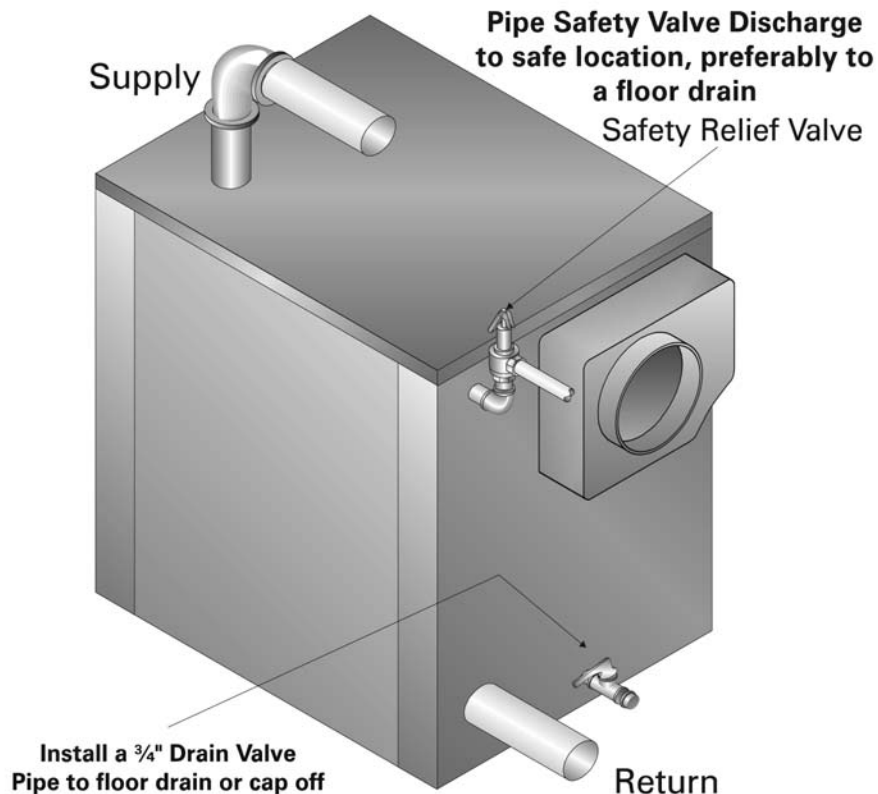


Figure 8.1: Safety Relief Valve Piping

## INSTALL CONTROLS AND TRIM

3. Mount the High Limit Control bulb well in the left side 3/4" tapping of the coil cover plate if a tankless heater is not mounted in the upper right opening (Position 2). If a coil is installed there, mount the well in the 3/4" tapping to the left of the opening. See Figure 8.2.

### CAUTION

**Make sure that the gas ignition system components, electrical controls, junction boxes and electrical panels are protected from water (dripping, spraying, rain, etc.) during boiler operation and service (circulator or pump servicing, control replacements or other).**

### E. PIPE TANKLESS HEATERS IF USED

1. Connect piping to any installed tankless heaters. See Figure 8.3 for suggested piping for single coils and Figure 8.4 for suggested piping for dual coils.

### F. CONNECT SUPPLY WIRING

1. Install all wiring in accordance with local codes, the National Electrical Code and other controlling agencies or governing bodies.
2. Use #14 gauge or heavier wire for supply wiring. Protect the circuit with a fused disconnect switch (by others).

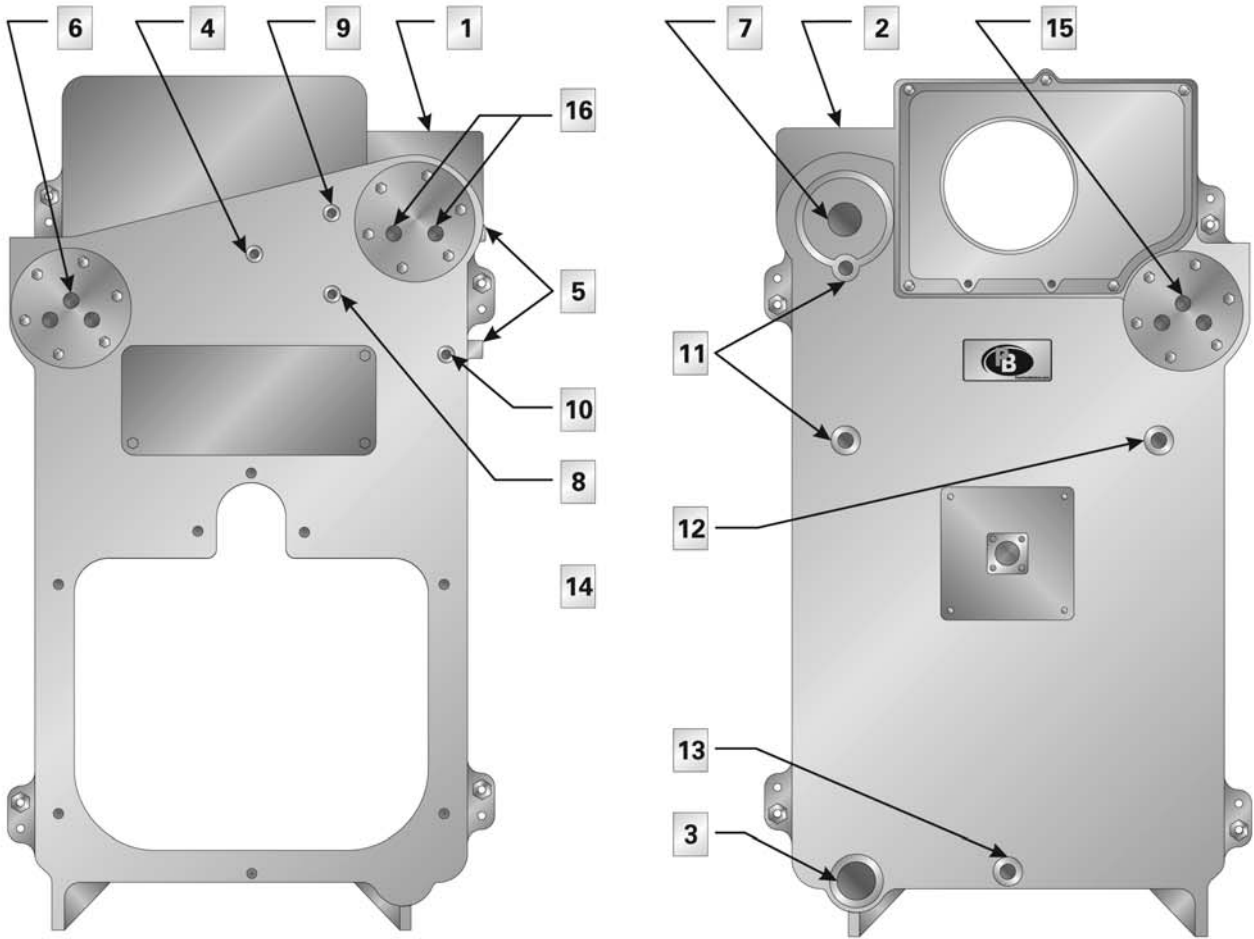
### CAUTION

**The boiler/burner must be electrically grounded in accordance with the requirements of the authority having jurisdiction, or in the absence of such requirements, with the current edition of the National Electrical Code, ANSI/NFPA Number 70.**

3. Follow the instructions in the Burner Manual and the Wiring Diagrams supplied with the burner and the boiler.

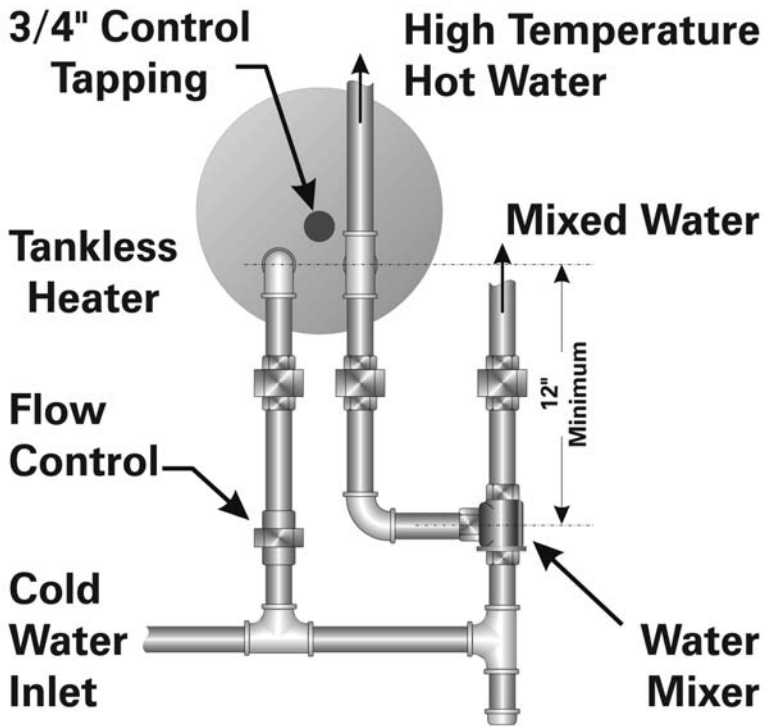
### G. INSTALL CONTROL WIRING

1. Wire the boiler according to the wiring diagrams supplied with the burner and the boiler (in the Boiler Envelope).
2. Low Energy Safety Control wiring, if used, must follow the contour of the boiler. Some local codes may require that all wiring, even low voltage, be routed in conduit.
3. Install line voltage wiring in conduit.
4. Do not install single pole switches, including safety controls, in a grounded line.



<b>1</b>	<b>4" NPT Supply Tapping, Front Section</b>	<b>8</b>	<b>Probe LWCO Tapping, 3/4" NPT</b>
<b>2</b>	<b>4" NPT Supply Tapping, Rear Section</b>	<b>9</b>	<b>Alternate High Temp Limit Location, 3/4" NPT Tapping</b>
<b>3</b>	<b>3" NPT Return Tapping, Rear Section</b>	<b>10</b>	<b>Not used on water, 3/4" NPT – Plug Tapping</b>
<b>4</b>	<b>Pressure/Temp Gauge, 1/2" NPT Tapping</b>	<b>11</b>	<b>Float LWCO Tappings, 1" NPT</b>
<b>5</b>	<b>Not Used on Water, 1/2" NPT – Plug Tapping</b>	<b>12</b>	
<b>6</b>	<b>Tankless Coil Temp Control Tapping, 3/4" NPT, Not Used on Water – Plug</b>	<b>13</b>	<b>Drain Valve Connection, 3/4" NPT</b>
<b>7</b>	<b>Relief Valve Tapping, 2-1/2" NPT</b>	<b>14</b>	<b>Not Shown – 1" NPT Tapping in Side and Top of First Intermediate – for Float LWCO</b>
<b>16</b>	<b>Control Tapping, 3/4" NPT – Both limits in special tapped plate if no tankless coil in opening. Operating Limit Control here if Coil Installed</b>	<b>15</b>	<b>Tankless Coil Temp Control Tapping, 3/4" NPT Only with Optional Tkls Coil Back Section</b>

**Figure 8.2: Control and Pipe Tapping Locations**

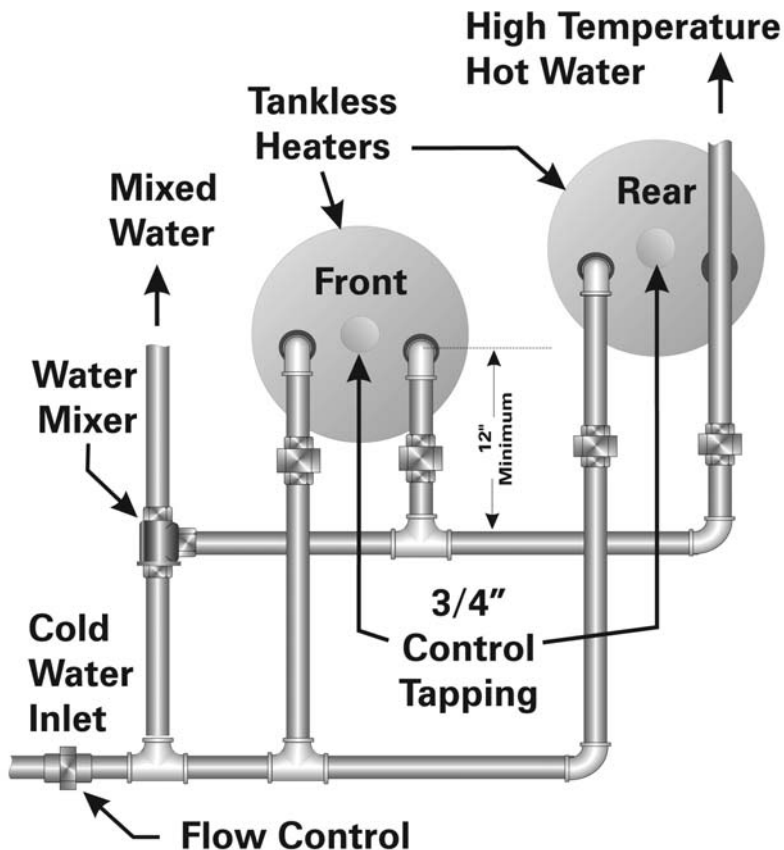


**⚠ DANGER**

Provide anti-scald devices in the system where needed.

Failure to control water temperature to showers or other usage areas where a scald risk exists can result in severe personal injury.

**Figure 8.3: Suggested Piping – Single Tankless Coil Installation**



**Figure 8.4: Suggested Piping – Dual Tankless Coil Installation**

## 9. STARTING THE BOILER

### A. CHECK THE PIPING

1. Water Piping
  - a) The Boiler must have been hydrostatically tested.
  - b) Check the attached piping for joint tightness.
  - c) Continue monitoring as you proceed through start up.
2. Gas Piping
  - a) Make sure the gas system piping and the connections to the boiler Gas Control Train(s) have been leak tested.
  - b) After the boiler is in operation, check the tightness of all joints in the boiler gas piping with a soap suds solution.
  - c) Purge the gas piping of all air up to the boiler Gas Control Train.
3. Oil Piping
  - a) Check the oil piping visually. Make sure all joints are tight.
  - b) When the burner is firing, check the suction line and return line pressures.
  - c) If the pressure exceeds the allowable pressure in the Burner Manual or if the suction line vacuum is higher than allowable, correct the piping as needed to bring the suction line and return line pressures within acceptable range.
  - d) Excess pressure can cause pump seal failures. Excess vacuum will cause fuel flow problems with the burner oil pump.

### B. FILL THE BOILER

1. Fill the boiler and system.
  - a) Fill the system with fresh water only. If the water hardness is high, use water treatment to reduce the deposition of minerals in the boiler.

#### CAUTION

**Check the system for leaks and make sure the automatic fill valve (if used) and the expansion tank are operating correctly. Leakage or weeping of the relief valve will cause make-up water to be added to the system. Excessive make-up water will damage the boiler and system components due to liming and oxygen corrosion.**

- b) If the system requires antifreeze, use only antifreeze designed for hydronic systems. These contain inhibitors to prevent corrosion of the boiler and system components. Do not use ethylene glycol or automotive antifreezes.
  - Make sure the antifreeze supplier can provide periodic inhibitor check service.

- If automatic fill is used, the system will have to be checked periodically to make sure the antifreeze concentration has not been diluted below design level.
- Local codes may require the use of a backflow preventer or manual fill only with separation from the city supply.
- Consider the minimum temperature of potential exposure for the system when deciding on the antifreeze concentration. A concentration of 50% generally provides protection from freezing down to -30°F.

#### CAUTION

**The boiler gaskets will be damaged by petroleum or its derivatives.**

**Do not use petroleum based compounds in the boiler, including petroleum-based stop-leak compounds.**

2. Purge the air from the system.

### C. RUN BURNER CHECK-OUT

1. Before firing the burner, slide the Slide Gate Damper on the rear flue box all the way down (full open) on LC's or open the LCE Draft Damper until the handle is parallel to the vent pipe (full open).
2. Follow the instructions in the Burner Manual for starting the burner, adjusting air openings and fuel rates. Perform ignition system and flame supervisory control test and checkout as described in the manual.
3. After burner is set at rate, close the damper until the pressure reading at the test opening in the rear flue box or draft damper is between 0" wc and 0.1" wc positive. See Table 9.1 for typical overfire pressure (measured at the burner front plate) and boiler draft loss.

When a barometric draft regulator is installed in the venting system, adjust the boiler damper for 0" wc pressure reading at the damper. Adjust the draft regulator for -0.05" wc draft between the boiler damper and the draft regulator.

#### CAUTION

**On installations with high draft, do not leave the boiler with a negative draft reading at the rear flue box or draft damper. High negative draft can pull the flame up into the boiler crown sheet and overheat the iron. This can result in cracked sections or shortened boiler life.**

## STARTING THE BOILER

4. Adjust the burner as needed for a CO<sub>2</sub> reading of:
    - a) Oil burners: CO<sub>2</sub> approximately 12.5% or 1% less than the level at which the smoke reading goes above a trace on the Bacharach scale.
    - b) Gas burners: 9% to 10% with CO less than 50 ppm.
    - c) Inspect all flue gas joints (sections, attachments, breeching and vent) for gas tightness. Remove the jacket panels in order to thoroughly inspect all rope seal joints between the sections.
- D. CHECK BOILER CONTROLS**
1. Limit and Operating Temperature Controls
    - a) Lower the setting of each control until the burner shuts down.
  2. Low Water Cutoffs
    - a) Test probe type controls by using the Push-to-Test Button.
    - b) Test float type controls. ASME CSD-1 requires the control to be piped with Test-n-Check valves in order to allow isolation for test.
  3. Follow additional instructions in the Burner Manual for proving the burner component operation.
  4. Check all controls to make sure they function correctly.
  5. After all controls have been proven, set the Operating and High Limit Temperature Controls to the temperatures desired.

**Table 9.1: Typical Combustion Chamber Pressure and Boiler Draft Loss**

Model	Combustion Chamber Pressure with 0.1" w.c. at Rear Flue Box Test Port (Inches w.c.)	Boiler Draft Loss (Inches w.c.)
LC-04	+ 0.22	0.12
LC-05R	+ 0.22	0.12
LC-05	+ 0.24	0.14
LC-06	+ 0.26	0.16
LC-07	+ 0.27	0.17
LC-08	+ 0.28	0.18
LC-09	+ 0.29	0.19
LC-10	+ 0.30	0.20
LC-11	+ 0.31	0.21
LC-12	+ 0.32	0.22
LCE-13	+ 0.24	0.14
LCE-14	+ 0.25	0.15
LCE-15	+ 0.26	0.16
LCE-16	+ 0.27	0.17
LCE-17	+ 0.28	0.18
LCE-18	+ 0.29	0.19
LCE-19	+ 0.30	0.20
LCE-20	+ 0.31	0.21
LCE-21	+ 0.31	0.21
LCE-22	+ 0.31	0.21
LCE-23	+ 0.32	0.22
LCE-24	+ 0.32	0.22

NOTE: Actual chamber pressure and draft loss readings may vary with each boiler and installation due to variation in the heat exchanger, deposits in the flueways, actual burner firing rate and excess air conditions. Use the above numbers as a general guide only. If the measured draft loss is considerably higher than the above, check the flueways for deposits and confirm the burner firing rate.



# 10. MAINTENANCE

## WARNING

### Product Safety Information Refractory Ceramic Fiber Product

This appliance contains materials made from refractory ceramic fibers (RCF). Airborne RCF, when inhaled, have been classified by the International Agency for Research on Cancer (IARC), as a possible carcinogen to humans. After the RCF materials have been exposed to temperatures above 1800°F (982°C), they can change into crystalline silica, which has been classified by the IARC as carcinogenic to humans. If particles become airborne during service or repair, inhalation of these particles may be hazardous to your health.

#### Avoid Breathing Fiber Particulates and Dust

Suppliers of RCF recommend the following precautions be taken when handling these materials:

#### Precautionary Measures:

Provide adequate ventilation.

Wear a NIOSH/MSHA approved respirator.

Wear long sleeved, loose fitting clothing and gloves to prevent skin contact.

Wear eye goggles.

Minimize airborne dust prior to handling and removal by water misting the material and avoiding unnecessary disturbance of materials.

Wash work clothes separately from others. Rinse washer thoroughly after use.

Discard RCF materials by sealing in an airtight plastic bag.

#### First Aid Procedures:

**Inhalation:** If breathing difficulty or irritation occurs, move to a location with fresh clean air. Seek immediate medical attention if symptoms persist.

**Skin Contact:** Wash affected area gently with a mild soap and warm water. Seek immediate medical attention if irritation persists.

**Eye Contact:** Flush eyes with water for 15 minutes while holding eyelids apart. Do not rub eyes. Seek immediate medical attention if irritation persists.

**Ingestion:** Drink 1 to 2 glasses of water. Do not induce vomiting. Seek immediate medical attention.

## **WARNING**

**Do not store or allow combustible or flammable materials near the boiler. Substantial fire or explosion hazard could result, causing risk of personal injury, death or property damage.**

**Do not use this boiler if any part of it has been under water. Immediately call a qualified service technician to inspect the boiler. Any part of the control system, any gas control or any burner or gas component which has been under water must be replaced.**

**Should overheating occur or the fuel supply fail to shut off: Shut off the fuel supply at a location external to the boiler. Do not turn off or disconnect the electrical supply to the pump. Immediately call a qualified service technician to inspect the boiler for damage and defective components.**

### **A. PLACING BOILER IN OPERATION**

1. Start up the Burner/Boiler per the Burner Manual and the instructions in this manual on starting the boiler.
2. Prove the correct operation of all controls on the boiler and burner as outlined below.
3. Check the operation of the ignition and flame proving controls as described in the Burner Manual.
4. Test the limit and operating controls to assure they are operating correctly.
5. Inspect and test all low water cutoffs.
6. Test the safety relief valve(s) using the procedure given by the valve manufacturer on the valve tag.
7. Visually inspect the burner and pilot flames (if applicable).

### **B. TO SHUT DOWN THE BOILER**

1. Turn off Burner.
2. Open main line power disconnect switch to boiler/burner.
3. Close fuel shut-off valves.
4. To take boiler out of service if the boiler and system are not to be used when temperatures are below freezing:
  - a) Drain the boiler and system completely and shut off make-up water supply.
  - b) Open main line power disconnect switch to boiler/burner. Remove the fuses or secure the switch so that the power cannot be turned on accidentally.

- c) Be certain that the boiler and system are refilled before returning to service. Follow the Instructions in this manual and the Lighting Instructions to operate.
- d) The system may be filled with a 50% inhibited propylene glycol solution for protection down to -35°F. Use only antifreeze solutions specifically designed for hydronic use.

### **C. MAINTENANCE – ANNUAL**

1. **Before the start of each heating season**, inspect and make all necessary adjustments to insure proper boiler and burner operation. Use the maintenance and inspection procedures following.
2. Inspect the Venting System
  - a) Check the chimney or vent to make sure it is clean and free from cracks or potential leaks.

## **CAUTION**

**Before servicing the boiler:**

- **Turn off all electrical power to the boiler.**
- **Close the Gas Service Valve and Oil Shut-Off Valve.**
- **Allow the boiler to cool if it has been operating.**
- **Label all wires prior to disconnection when servicing controls. Wiring errors can cause improper and dangerous operation. Verify proper operation after servicing.**

- b) All joints must be tight and sealed.
- c) The vent connector must extend into, but not beyond the inside edge of the chimney or vent.
3. Inspect the Boiler Area
  - a) The boiler area must be clean and free from combustible materials, gasoline or any other flammable liquids or vapors.
  - b) The combustion air openings and the area around the boiler must be unobstructed.
4. Inspect boiler flueways and burner for cleanliness. If cleaning is required, use the following procedure.
  - a) Turn off all electrical power to the boiler.
  - b) Remove Jacket Middle Front Panel and Jacket Top Panels. Remove Front Cleanout Plate and Cleanout Cover Plates on each flueway. On LCE boilers, remove the top flue outlet plate and vent piping as necessary to access the top of the sections.
  - c) Brush the boiler tube spaces both horizontally (through cleanout openings on ends) and vertically (from top of boiler through cleanout openings at flueways).

- d) Remove the Burner and Burner Mounting Plate. Remove any scale or soot from the combustion chamber by means of vacuum cleaning or other available means. Take care not to damage the chamber floor liner or target wall liner.
  - e) Replace the Front Cleanout Plate, Burner Mounting Plate, Burner and all Cleanout Cover Plates on top of the sections. Make sure all sealing rope and seals are in good condition. Replace sealing rope if necessary.
  - f) Replace all Jacket Panels.
5. Inspect the boiler and piping for signs of leaks. Check to see if there are signs of heavy make-up water addition to the system.
  6. When placing boiler into operation, follow Burner Manual, all instructions supplied with the boiler and the instructions in this chapter.
  7. Test the operation of all limit controls, float controls and ignition components as described in Part A, "Placing Boiler in Operation", of this chapter.

**D. MONTHLY MAINTENANCE**

1. Inspect the burner and pilot flames as for the annual inspection.
2. Inspect the boiler and system for any signs of leakage or excessive make-up water usage.
3. Inspect and check the operation of the venting system.

**E. DAILY MAINTENANCE**

1. Inspect the boiler area to make sure the area is free from combustible or flammable materials and that there are not obstructions to the flow of air to the boiler or combustion air openings to the room.
2. Make sure there are no signs of abnormal operation, such as overfilling or leakage.



**CAUTION**

**Be very careful when adding water to a hot boiler. Add very slowly or, if possible, allow the boiler to cool naturally before adding water.**

**If an excessive loss of water occurs, check for a leak in the piping and correct the problem. Excessive make-up water will cause corrosion and damage to the boiler.**

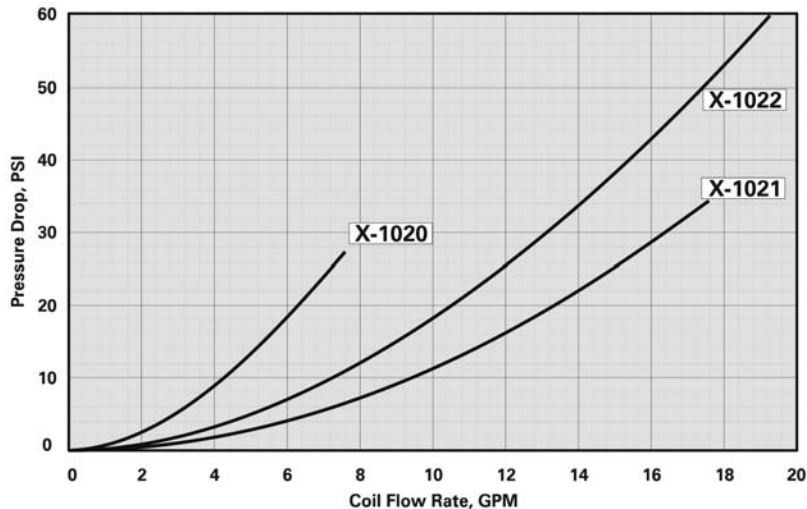
# 11. BOILER RATINGS & DIMENSIONS



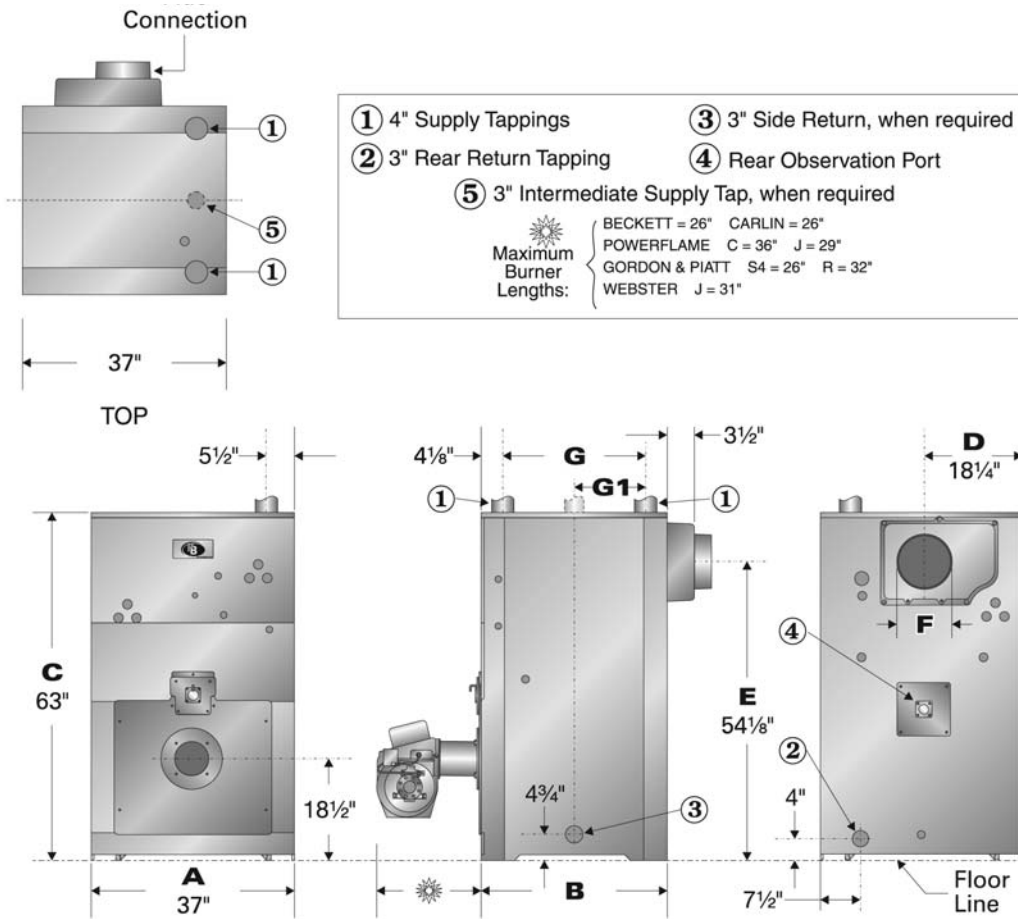
**Table 11.1: Series LC/LCE Boiler Ratings**

SERIES LC/LCE BOILER RATINGS									
Boiler Model Number	Gross I=B=R Output Mbh	Boiler H.P.	I=B=R Burner Capacity		I=B=R Net Ratings			Combustion Efficiency	
			Oil GPH	Gas MBH	Steam Sq. Ft.	Steam MBH	Water MBH	Oil	Gas
LC-04	547	16.3	4.75	686	1708	410	476	83.7	81.2
LC-05R	649	19.4	5.60	808	2029	487	564	83.7	81.2
LC-05	707	21.1	6.10	881	2208	530	615	83.7	81.2
LC-06	868	25.7	7.50	1077	2713	651	755	83.7	81.1
LC-07	1029	30.7	8.80	1273	3217	772	895	83.6	81.1
LC-08	1189	35.5	10.20	1469	3717	892	1034	83.6	81.1
LC-09	1350	40.3	11.60	1664	4250	1020	1174	83.6	81.1
LC-10	1511	45.1	12.80	1860	4804	1153	1314	83.6	81.1
LC-11	1672	49.9	14.20	2056	5367	1288	1454	83.6	81.1
LC-12	1832	54.7	15.60	2252	5917	1420	1593	83.6	81.1
LCE-13	1966	58.7	17.00	2464	6358	1526	1710	83.5	81.0
LCE-14	2125	63.5	18.40	2657	6875	1650	1848	83.5	81.0
LCE-15	2284	68.2	19.80	2850	7388	1773	1986	83.5	81.0
LCE-16	2444	73.0	21.00	3043	7908	1898	2125	83.5	81.0
LCE-17	2603	77.8	22.50	3236	8421	2021	2263	83.5	81.0
LCE-18	2763	82.5	24.00	3429	8938	2145	2403	83.5	81.0
LCE-19	2922	87.3	25.00	3622	9454	2269	2541	83.5	81.0
LCE-20	3082	92.1	26.50	3815	9971	2393	2680	83.5	81.0
LCE-21	3256	97.3	28.00	4027	10533	2528	2831	83.6	81.1
LCE-22	3430	102.5	29.50	4239	11096	2663	2983	83.6	81.1
LCE-23	3604	107.7	31.00	4451	11658	2798	3134	83.7	81.2
LCE-24	3777	112.8	32.50	4663	12217	2932	3284	83.7	81.2

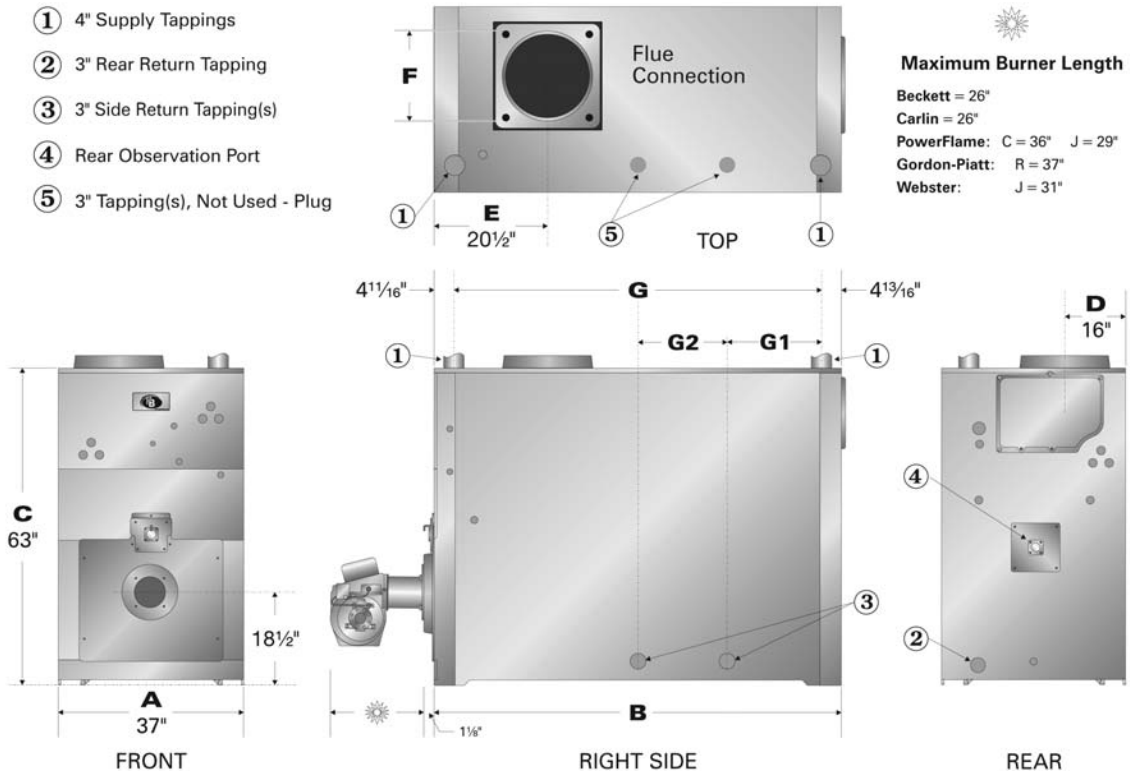
- 1 Burner input based on No. 2 fuel oil with a heating value of 140,000 Btu per gallon.
- 2 Net I=B=R water ratings based on an allowance of 1.15.
- 3 Net I=B=R steam ratings based on an allowance for LC-04 to LC-08=1.333, LC-09=1.323, LC-10=1.310, LC-11=1.298, LC-12=1.290, LCE-13 to LCE-24=1.288.
- 4 Consult factory before selecting a boiler for installations having unusual piping and pickup requirements, such as intermittent system operation, extensive piping systems, etc.
- 5 Combustion efficiency determined in accordance with The Hydronics Institute's Testing and Rating Standard for Heating Boilers.



**Figure 11.1: Tankless Coil Pressure Drops**



**Figure 11.2: Series LC Dimensional Diagram**



**Figure 11.3: Series LCE Dimensional Diagram**

**Table 11.2: Series LC/LCE Boiler Dimensions**

Boiler Model Number	Jacket		Supply Piping			Return Piping			Riser Tapping Locations*				Vent Location		Vent	
	Width "A"	Length "B"	Height "C"	Number	Size	Recom. Header	Number	Size	Recom. Header	Ends "G"	Intermediate Section Tapping		"D"	"E"	Diameter	Minimum Height
											"G1"	"G2"				
LC-04	37"	25 <sup>15</sup> / <sub>16</sub> "	63"	1	2 <sup>1</sup> / <sub>2</sub> "	2 <sup>1</sup> / <sub>2</sub> "	1	2 <sup>1</sup> / <sub>2</sub> "	2 <sup>1</sup> / <sub>2</sub> "	16 <sup>1</sup> / <sub>2</sub> "	-	-	18 <sup>1</sup> / <sub>2</sub> "	54 <sup>1</sup> / <sub>8</sub> "	9"	3'
LC-05R	37"	31"	63"	1	2 <sup>1</sup> / <sub>2</sub> "	2 <sup>1</sup> / <sub>2</sub> "	1	2 <sup>1</sup> / <sub>2</sub> "	2 <sup>1</sup> / <sub>2</sub> "	21 <sup>9</sup> / <sub>16</sub> "	-	-	18 <sup>1</sup> / <sub>2</sub> "	54 <sup>1</sup> / <sub>8</sub> "	9"	3'
LC-05	37"	31"	63"	1	2 <sup>1</sup> / <sub>2</sub> "	2 <sup>1</sup> / <sub>2</sub> "	1	2 <sup>1</sup> / <sub>2</sub> "	2 <sup>1</sup> / <sub>2</sub> "	21 <sup>9</sup> / <sub>16</sub> "	-	-	18 <sup>1</sup> / <sub>2</sub> "	54 <sup>1</sup> / <sub>8</sub> "	9"	3'
LC-06	37"	36 <sup>1</sup> / <sub>16</sub> "	63"	1	3"	3"	1	3"	3"	26 <sup>5</sup> / <sub>8</sub> "	-	-	18 <sup>1</sup> / <sub>2</sub> "	54 <sup>1</sup> / <sub>8</sub> "	10"	3'
LC-07	37"	41 <sup>1</sup> / <sub>8</sub> "	63"	1	3"	3"	1	3"	3"	31 <sup>1</sup> / <sub>16</sub> "	-	-	18 <sup>1</sup> / <sub>2</sub> "	54 <sup>1</sup> / <sub>8</sub> "	10"	3'
LC-08	37"	46 <sup>5</sup> / <sub>16</sub> "	63"	2	3"	3"	2	3"	3"	36 <sup>3</sup> / <sub>16</sub> "	15 <sup>3</sup> / <sub>16</sub> "	-	18 <sup>1</sup> / <sub>2</sub> "	54 <sup>1</sup> / <sub>8</sub> "	10"	3'
LC-09	37"	51 <sup>3</sup> / <sub>8</sub> "	63"	2	3"	3"	2	3"	3"	41 <sup>7</sup> / <sub>8</sub> "	20 <sup>15</sup> / <sub>16</sub> "	-	18 <sup>1</sup> / <sub>2</sub> "	54 <sup>1</sup> / <sub>8</sub> "	12"	3'
LC-10	37"	56 <sup>7</sup> / <sub>16</sub> "	63"	2	3"	4"	2	3"	4"	46 <sup>15</sup> / <sub>16</sub> "	20 <sup>15</sup> / <sub>16</sub> "	-	18 <sup>1</sup> / <sub>2</sub> "	54 <sup>1</sup> / <sub>8</sub> "	12"	3'
LC-11	37"	61 <sup>1</sup> / <sub>2</sub> "	63"	2	3"	4"	2	3"	4"	52"	26"	-	18 <sup>1</sup> / <sub>2</sub> "	54 <sup>1</sup> / <sub>8</sub> "	12"	3'
LC-12	37"	66 <sup>9</sup> / <sub>16</sub> "	63"	2	3"	4"	2	3"	4"	57 <sup>1</sup> / <sub>8</sub> "	26"	-	18 <sup>1</sup> / <sub>2</sub> "	54 <sup>1</sup> / <sub>8</sub> "	12"	3'
LCE-13	37"	71 <sup>3</sup> / <sub>4</sub> "	63"	2	4"	4"	2	3"	4"	62 <sup>3</sup> / <sub>16</sub> "	36 <sup>3</sup> / <sub>16</sub> "	-	18 <sup>1</sup> / <sub>2</sub> "	20 <sup>1</sup> / <sub>2</sub> "	14"	3'
LCE-14	37"	76 <sup>13</sup> / <sub>16</sub> "	63"	2	4"	4"	2	3"	4"	67 <sup>1</sup> / <sub>4</sub> "	41 <sup>1</sup> / <sub>4</sub> "	-	18 <sup>1</sup> / <sub>2</sub> "	20 <sup>1</sup> / <sub>2</sub> "	14"	3'
LCE-15	37"	81 <sup>7</sup> / <sub>8</sub> "	63"	2	4"	4"	2	3"	4"	72 <sup>5</sup> / <sub>16</sub> "	46 <sup>3</sup> / <sub>8</sub> "	-	18 <sup>1</sup> / <sub>2</sub> "	20 <sup>1</sup> / <sub>2</sub> "	14"	3'
LCE-16	37"	86 <sup>15</sup> / <sub>16</sub> "	63"	2	4"	4"	2	3"	4"	77 <sup>7</sup> / <sub>16</sub> "	51 <sup>7</sup> / <sub>16</sub> "	-	18 <sup>1</sup> / <sub>2</sub> "	20 <sup>1</sup> / <sub>2</sub> "	14"	3'
LCE-17	37"	92 <sup>1</sup> / <sub>8</sub> "	63"	2	4"	5"	2	3"	5"	82 <sup>1</sup> / <sub>2</sub> "	41 <sup>1</sup> / <sub>4</sub> "	-	18 <sup>1</sup> / <sub>2</sub> "	20 <sup>1</sup> / <sub>2</sub> "	14"	3'
LCE-18	37"	97 <sup>3</sup> / <sub>16</sub> "	63"	2	4"	5"	2	3"	5"	87 <sup>9</sup> / <sub>16</sub> "	41 <sup>1</sup> / <sub>4</sub> "	-	18 <sup>1</sup> / <sub>2</sub> "	20 <sup>1</sup> / <sub>2</sub> "	16"	3'
LCE-19	37"	102 <sup>1</sup> / <sub>4</sub> "	63"	2	4"	5"	2	3"	5"	92 <sup>5</sup> / <sub>8</sub> "	41 <sup>1</sup> / <sub>4</sub> "	-	18 <sup>1</sup> / <sub>2</sub> "	20 <sup>1</sup> / <sub>2</sub> "	16"	3'
LCE-20	37"	107 <sup>7</sup> / <sub>16</sub> "	63"	2	4"	5"	2	3"	5"	97 <sup>3</sup> / <sub>4</sub> "	41 <sup>1</sup> / <sub>4</sub> "	-	18 <sup>1</sup> / <sub>2</sub> "	20 <sup>1</sup> / <sub>2</sub> "	16"	3'
LCE-21	37"	112 <sup>1</sup> / <sub>2</sub> "	63"	2	4"	5"	2	3"	5"	102 <sup>13</sup> / <sub>16</sub> "	41 <sup>1</sup> / <sub>4</sub> "	35 <sup>9</sup> / <sub>16</sub> "	18 <sup>1</sup> / <sub>2</sub> "	20 <sup>1</sup> / <sub>2</sub> "	16"	3'
LCE-22	37"	117 <sup>9</sup> / <sub>16</sub> "	63"	2	4"	5"	2	3"	5"	107 <sup>7</sup> / <sub>8</sub> "	41 <sup>1</sup> / <sub>4</sub> "	40 <sup>5</sup> / <sub>8</sub> "	18 <sup>1</sup> / <sub>2</sub> "	20 <sup>1</sup> / <sub>2</sub> "	16"	3'
LCE-23	37"	122 <sup>5</sup> / <sub>8</sub> "	63"	2	4"	5"	2	3"	5"	112 <sup>13</sup> / <sub>16</sub> "	46 <sup>3</sup> / <sub>8</sub> "	40 <sup>5</sup> / <sub>8</sub> "	18 <sup>1</sup> / <sub>2</sub> "	20 <sup>1</sup> / <sub>2</sub> "	16"	3'
LCE-24	37"	127 <sup>1</sup> / <sub>16</sub> "	63"	2	4"	5"	2	3"	5"	118 <sup>1</sup> / <sub>16</sub> "	46 <sup>3</sup> / <sub>8</sub> "	45 <sup>1</sup> / <sub>16</sub> "	18 <sup>1</sup> / <sub>2</sub> "	20 <sup>1</sup> / <sub>2</sub> "	16"	3'

\*These dimensions are approximate.

## 12. REPAIR PARTS

Repair parts are available from your installer or by contacting PB Heat, LLC, New Berlinville, PA. Use the Figures and Tables on pages 45-50 to assist in ordering parts.

Note: Remember to include boiler model number and serial number when ordering parts.

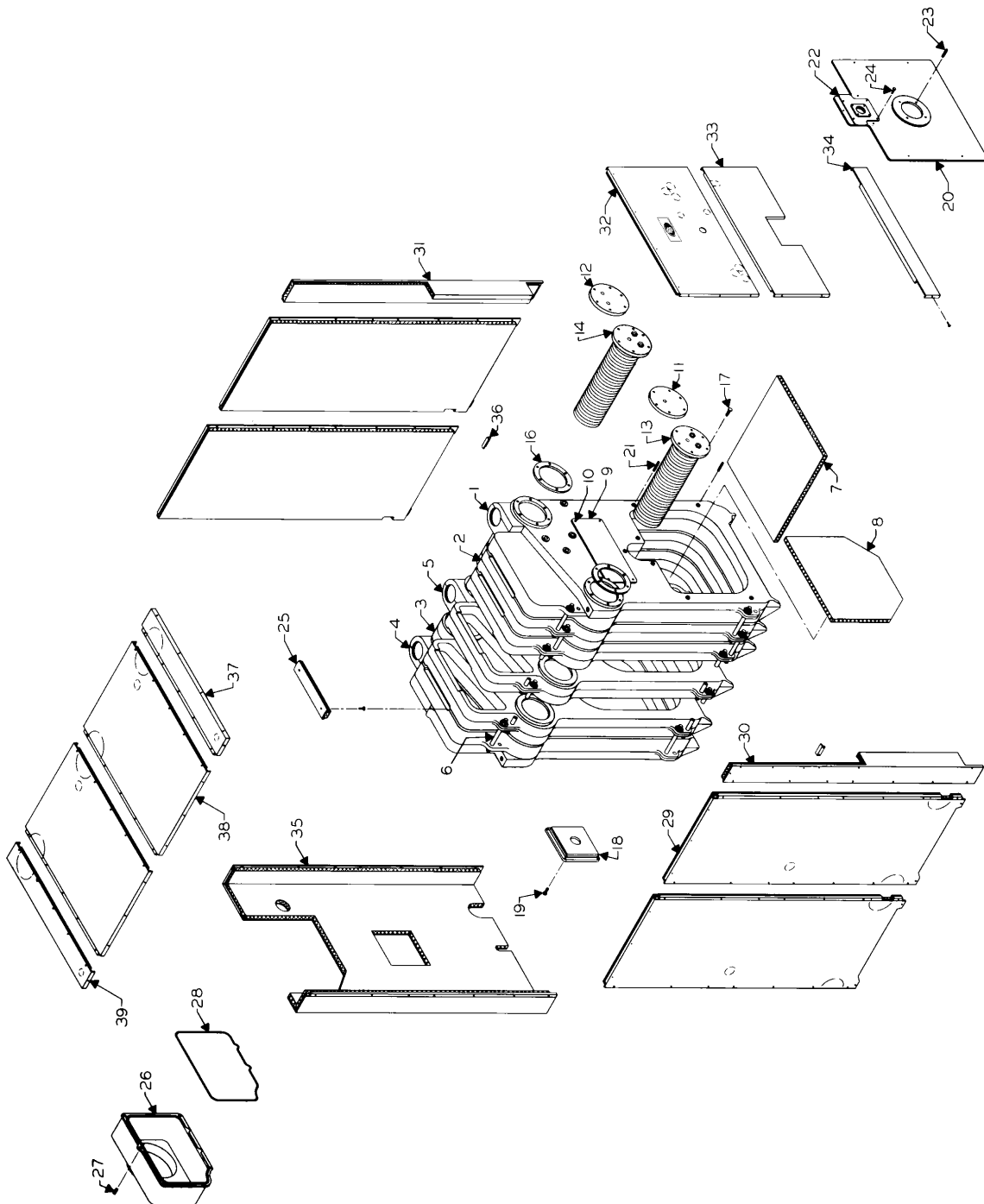


Figure 12.1: Series LC Boiler Assembly

## REPAIR PARTS

**Table 12.1A: Series LC Repair Parts**

Item No.	Description	Part Selection Information	Stock Code
1	Front Section	See Table 3 for Stock Code	-
2	Intermediate Section w/1" Tapping	See Table 3 for Stock Code	-
3	Intermediate Section	See Table 3 for Stock Code	-
4	Back Section	See Table 3 for Stock Code	-
5	Tapped Intermediate Section	See Table 3 for Stock Code	-
	Upper Flow Port Gasket	2 Required per Flueway	51671
	Lower Flow Port Gasket	1 Required per Flueway	51672
6	Tie Rod	4 Required per Flueway	51721
	5/8" Diameter High Temp Rope	13 Feet Required per Flueway	55723
7	Ceramic Fiber Base Liner	Models LC-04 through LC-12	50862
8	Ceramic Fiber Target Wall		50854
9	Front Cleanout Plate (C.I.)		51162
10	5/16"-18 x 1-1/4" Studs w/Brass Nuts	4 Required	
11	Steel Cover Plate		51776
12	Steel Cover Plate		51777
13	Tankless Heater Location 1	Specify Heater Model Number	
14	Tankless Heater Location 2	Specify Heater Model Number	
16	Rubber Gasket	Specify Quantity	51800
17	3/8"-16 x 3/4" SS Hex Head Cap Screw	Specify Quantity	
18	Rear Observation Assembly		90923
19	5/16"-18 x 3/4" Hex Head Cap Screw	Specify Quantity	
20	Burner Mounting Plate	Specify Burner Model	
21	3/8"-16 x 2-1/4" Studs with Nuts	7 Required	
22	Flame Observation Assembly		90922
23	3/8"-16 x 1" Studs for Burner Mounting	4 Required	
24	1/4"-20 x 1/2" Hex Head Machine Screw	4 Required	
25	Cleanout Cover Plate (Steel)	1 Required per Flueway	51772
26	Rear Flue Box w/9" Flue Outlet	Models LC-04 and LC-05	86040
	Rear Flue Box w/10" Flue Outlet	Models LC-06, LC-07 and LC-08	86041
	Rear Flue Box w/12" Flue Outlet	Models LC-09, LC-10, LC-11 and LC-12	86042
27	Rear Flue Box Stud 5/16"-18 x 1-1/2"	7 Required	
28	Rear Flue Box Hi Temp Rope, 1/4" Diameter x 65" Long		
29	Side Jacket Panel LC-6000	For Models LC-04 and LC-08	
	Side Jacket Panel LC-6001	For Models LC-05, LC-08, LC-09 and LC-10	
	Side Jacket Panel LC-6002	For Models LC-06, LC-10, LC-11 and LC-12	
	Side Jacket Panel LC-6003	For Models LC-07 and LC-12	
30	Left Front Jacket Corner Panel LC-6011		
31	Right Front Jacket Corner Panel LC-6010		
32	Upper Front Jacket Panel LC-6007		
33	Middle Front Jacket Panel LC-6008		
34	Lower Front Jacket Rail LC-6009		
35	Back Jacket Panel LC-6012		
36	Side Jacket Panel Support Angle LC-6014		
37	Front Top Jacket Panel LC-6005		



**Table 12.1B: Series LC Repair Parts (continued)**

Item No.	Description	Part Selection Information	Stock Code
38	Top Jacket Panel LC-6004	For Models LC-04 and LC-08	
	Top Jacket Panel LC6004-1	For Models LC-05, LC-08, LC-09 and LC-10	
	Top Jacket Panel LC-6004-2	For Models LC-06, LC-10, LC-11 and LC-12	
	Top Jacket Panel LC-6004-3	For Models LC-07 and LC-12	
39	Rear Top Jacket Panel LC-6006		
	Single Rib Flue Baffle, Aluminized Steel LC-1018	Specify Boiler Model Number	
	Triple Rib Flue Baffle, Aluminized Steel LC-1019	Specify Boiler Model Number	
	Single Rib Flue Baffle, Stainless Steel LC-1020	Specify Boiler Model Number	
	Triple Rib Flue Baffle, Stainless Steel LC-1021	Specify Boiler Model Number	

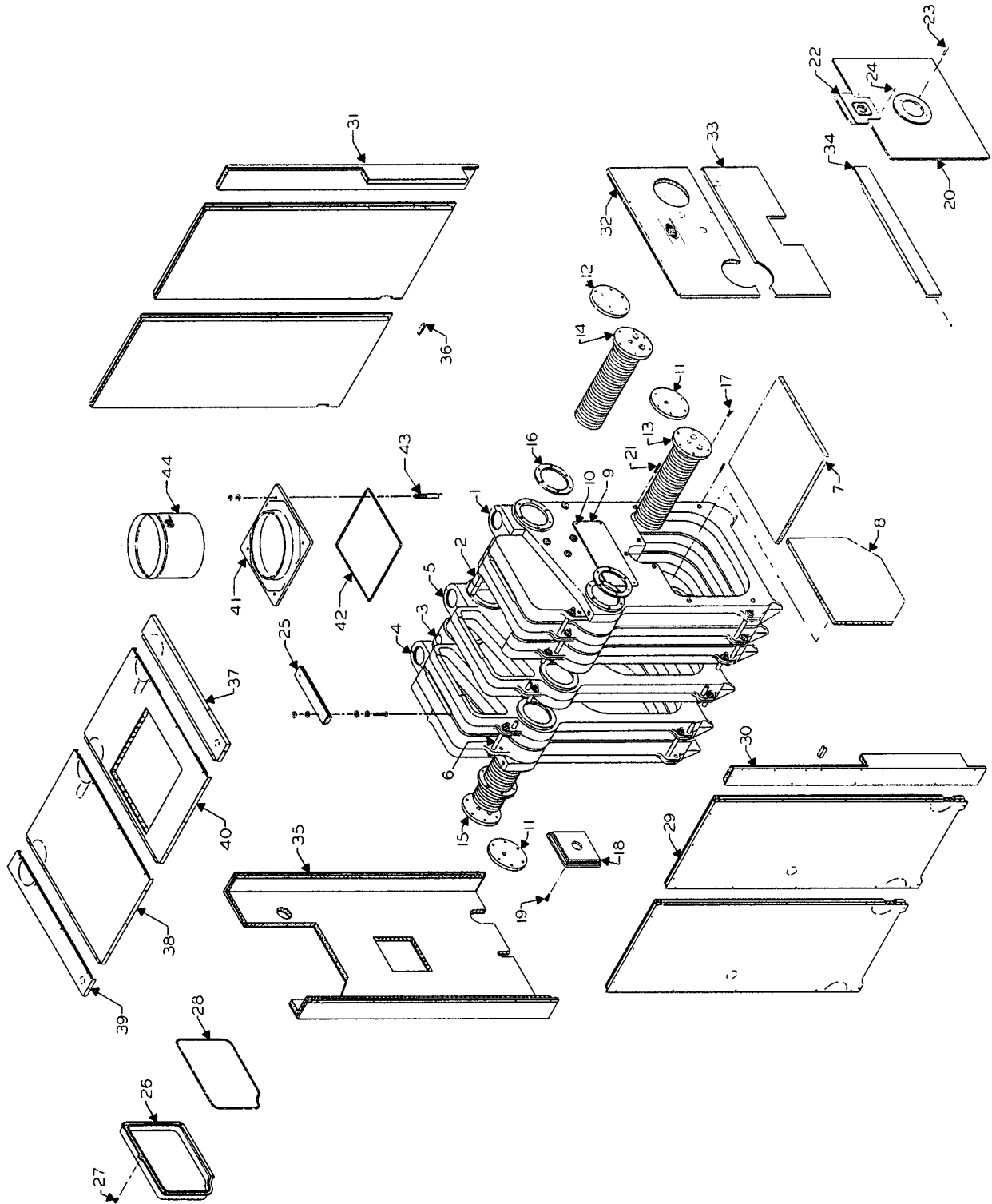


Figure 12.2: Series LCE Boiler Assembly

Table 12.2A: Series LCE Repair Parts

Item No.	Description	Part Selection Information	Stock Code
1	Front Section	See Table for Stock Code	-
2	Top Flue Outlet Intermediate Section		-
	Intermediate Section w/1" Tapping		-
3	Intermediate Section		-
4	Back Section (Closed Back)		86022
	Back Section w/Tankless Coil Opening		86036
5	Tapped Intermediate Section		86008
	Upper Flow Port Gasket	2 Required per Flueway	51671
	Lower Flow Port Gasket	1 Required per Flueway	51672
6	Tie Rod	4 Required per Flueway	51721
	5/8" Diameter High Temp Rope	13 Feet Required per Flueway	55723
7	Ceramic Fiber Base Liner	For All LCE Boilers	50862
8	Ceramic Fiber Target Wall		50854
9	Front Cleanout Plate (C.I.)		51162
10	5/16"-18 x 1-1/4" Studs w/Brass Nuts	4 Required	
11	Steel Cover Plate		51776
12	Steel Cover Plate		51777
13	Tankless Heater Location 1	Specify Heater Model Number	
14	Tankless Heater Location 2	Specify Heater Model Number	
15	Tankless Heater Location 3	Not Used on Water	
16	Rubber Gasket	Specify Quantity	51800
17	3/8"-16 x 3/4" SS Hex Head Cap Screw	Specify Quantity	
18	Rear Observation Assembly		90923
19	5/16"-18 x 3/4" Hex Head Cap Screw	Specify Quantity	
20	Burner Mounting Plate	Specify Burner Model	
21	3/8"-16 x 2-1/4" Studs with Nuts	7 Required	
22	Front Observation Assembly		90922
23	3/8"-16 x 1" Studs for Burner Mounting	4 Required	
24	1/4"-20 x 1/2" Hex Head Machine Screw	4 Required	
25	Cleanout Cover Plate (Steel)	1 Required per Flueway	51772
26	Rear Flue Cover Plate	For All LCE Boilers	51131
27	Rear Flue Cover Stud 5/16"-18 x 1-1/2"	5 Required	
28	Rear Flue Cover Hi Temp Rope, 1/4" Dia. x 65" Long		
29	Side Jacket Panel LC-6000	For Models LCE-13, -17, -20 & -21	
	Side Jacket Panel LC-6001	For Models LCE-13 to LCE-15, LCE-17 to LCE-24	
	Side Jacket Panel LC-6002	For All LCE Boilers	
30	Left Front Jacket Corner Panel LC-6011		
31	Right Front Jacket Corner Panel LC-6010		
32	Upper Front Jacket Panel LC-6007		
33	Middle Front Jacket Panel LC-6008		
34	Lower Front Jacket Rail LC-6009		
35	Back Jacket Panel LC-6012		
36	Side Jacket Panel Support Angle LC-6014		
37	Front Top Jacket Panel LC-6005		
38	Top Jacket Panel LC-6004	For Models LCE-13, -17, -20 & -21	
	Top Jacket Panel LC-6004-1	For Models LCE-13 to LCE-15, LCE-17 to LCE-24	

## REPAIR PARTS

**Table 12.2B: Series LCE Repair Parts (continued)**

Item No.	Description	Part Selection Information	Stock Code
38	Top Jacket Panel LC-6004-2	For Models LCE-15, -16, -19, -23 & -24	
40	Top Jacket Panel with Flue Opening LC-6022	For All LCE Boilers	
39	Rear Top Jacket Panel LC-6006		
41	Top Flue Outlet Plate (14" Flue)	For Models LCE-13 through LCE-17	51132
	Top Flue Outlet Plate (16" Flue)	For Models LCE-18 and Larger	51133
42	5/8" Diameter High Temperature Rope	For Top Flue Outlet Plate, 6 Feet	55723
43	3/8" Diameter Tie Down Assembly	For Top Flue Outlet Plate, 4 Required	51604
44	Draft Damper, 14"	For Models LCE-13 through LCE-17	90523
	Draft Damper, 16"	For Models LCE-18 and Larger	90524
	Baffles	Models LCE-21 through LCE-24 Only	86113





# Series LC/LCE

## *Oil, Gas & Gas/Oil Boilers Water*

### **Installation, Operation & Maintenance Manual**

**TO THE INSTALLER:**

*This manual is the property of the owner and must be affixed near the boiler for future reference.*

**TO THE OWNER:**

*This boiler should be inspected annually by a Qualified Service Agency.*



HI Division  
of gama



ASME



PeerlessBoilers.com

**PB HEAT, LLC**

PO BOX 447 • NEW BERLINVILLE, PA 19545-0447